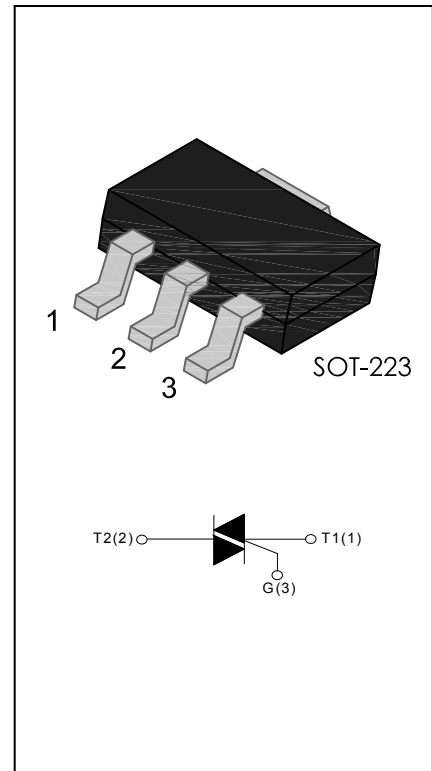

**BT134 Series 4A TRIACs**
**DESCRIPTION:**

B T134 series triacs with low holding and latching current are especially recommended for use on middle and small resistance type power load.

**MAIN FEATURES**

Symbol	Value	Unit
$I_{T(RMS)}$	4	A
$V_{DRM}/V_{RRM}$	600	V

**ABSOLUTE MAXIMUM RATINGS**

Parameter		Symbol	Value	Unit
Storage junction temperature range		$T_{stg}$	-40 - 150	°C
Operating junction temperature range		$T_j$	-40 - 125	°C
Repetitive peak off-state voltage( $T_j=25^\circ\text{C}$ )		$V_{DRM}$	600	V
Repetitive peak reverse voltage( $T_j=25^\circ\text{C}$ )		$V_{RRM}$	600	V
Non repetitive surge peak Off-state voltage		$V_{DSM}$	$V_{DRM} + 100$	V
Non repetitive peak reverse voltage		$V_{RSM}$	$V_{RRM} + 100$	V
RMS on-state current	SOT-223 ( $T_c=75^\circ\text{C}$ )	$I_{T(RMS)}$	4	A

Non repetitive surge peak on-state current (full cycle, F=50Hz)	$I_{TSM}$	25	A
$I^2t$ value for fusing ( $t_p = 10ms$ )	$I^2t$	3.1	$A^2s$
Critical rate of rise of on-state current ( $I_G = 2 \times I_{GT}$ )	I - II - III	50	$A/\mu s$
	IV	10	
Peak gate current	$I_{GM}$	2	A
Average gate power dissipation	$P_{G(AV)}$	0.5	W
Peak gate power	$P_{GM}$	5	W

**ELECTRICAL CHARACTERISTICS** ( $T_j = 25^\circ C$  unless otherwise specified)

Symbol	Test Condition	Quadrant		Value	Unit
				E	
$I_{GT}$	$V_D = 12V$ $R_L = 33\Omega$	I - II - III	MAX	5	mA
		IV		10	
$V_{GT}$		ALL	MAX	1.3	V
$V_{GD}$	$V_D = V_{DRM}$ $T_j = 125^\circ C$ $R_L = 3.3K\Omega$	ALL	MIN	0.2	V
$I_L$	$I_G = 1.2I_{GT}$	I - III - IV	MAX	10	mA
		II		15	
$I_H$	$I_T = 100mA$		MAX	10	mA
dV/dt	$V_D = 2/3V_{DRM}$ Gate Open $T_j = 125^\circ C$		MIN	50	$V/\mu s$
(dV/dt)c	(dI/dt)c = 1.1A/ms $T_j = 125^\circ C$		MIN	1	$V/\mu s$

**STATIC CHARACTERISTICS**

Symbol	Parameter		Value(MAX)	Unit
$V_{TM}$	$I_{TM} = 5A$ $t_p = 380\mu s$	$T_j = 25^\circ C$	1.7	V
$I_{DRM}$	$V_D = V_{DRM}$ $V_R = V_{RRM}$	$T_j = 25^\circ C$	5	$\mu A$
$I_{RRM}$		$T_j = 125^\circ C$	0.5	mA

THERMAL RESISTANCES

Symbol	Parameter		Value	Unit
$R_{th(j-c)}$	junction to case(AC)	SOT-223	4.5	°C/W

ORDERING INFORMATION

T

SIKA CO.,LIMITED	<b>B</b>	<b>T</b>	<b>134</b>	<b>W</b>	<b>- 600</b>	<b>E</b>
	TRIACs	$I_{T(RMS)}:4A$		W:SOT-223		$E : I_{GT} \leq 5mA \ I_{GT4} \leq 10mA$ $600 : V_{DRM}/V_{RRM} \geq 600V$

PACKAGE MECHANICAL DATA

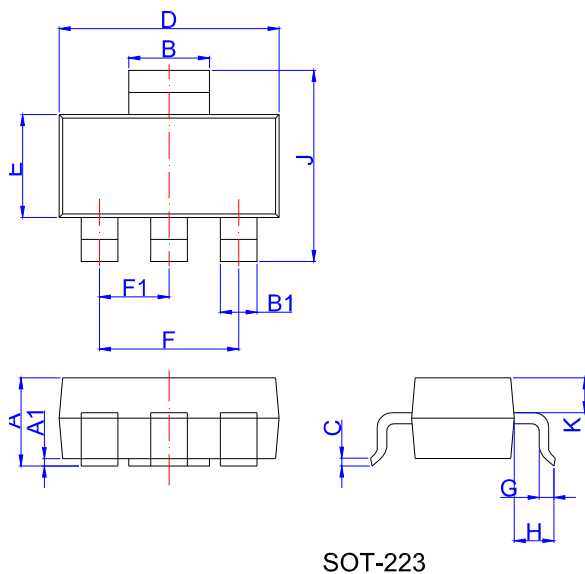

Ref.	Dimensions					
	Millimeters			Inches		
	Min.	Typ.	Max.	Min.	Typ.	Max.
A	1.5	1.6	1.8	0.059	0.063	0.071
A1	0.01	0.06	0.10	0.001	0.002	0.004
B	2.9	3.0	3.1	0.114	0.118	0.122
B1	0.6	0.7	0.8	0.024	0.028	0.031
C	0.22	0.26	0.32	0.009	0.010	0.013
D	6.3	6.5	6.7	0.248	0.256	0.264
E	3.3	3.5	3.7	0.130	0.138	0.146
F		4.6			0.181	
F1		2.3			0.091	
G	0.7	0.9	1.1	0.028	0.035	0.043
H	1.5	1.75	2.0	0.059	0.069	0.079
J	6.7	7.0	7.3	0.264	0.276	0.287
K	0.8	0.9	1.0	0.031	0.035	0.039

**FIG.1:** Maximum power dissipation versus RMS on-state current

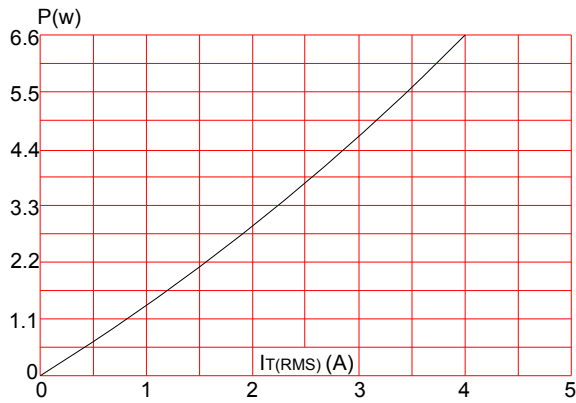

**FIG.3:** Surge peak on-state current versus number of cycles

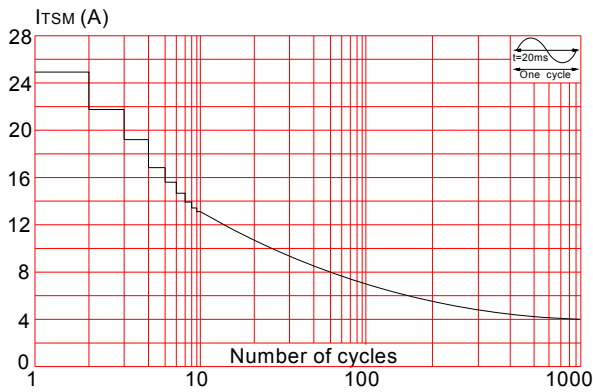

**FIG.5:** Non-repetitive surge peak on-state current for a sinusoidal pulse with width  $t_p < 20\text{ms}$  and corresponding value of  $I^2t$  ( I - II -III:  $dI/dt < 50\text{A}/\mu\text{s}$ ; IV:  $dI/dt < 10\text{A}/\mu\text{s}$ )

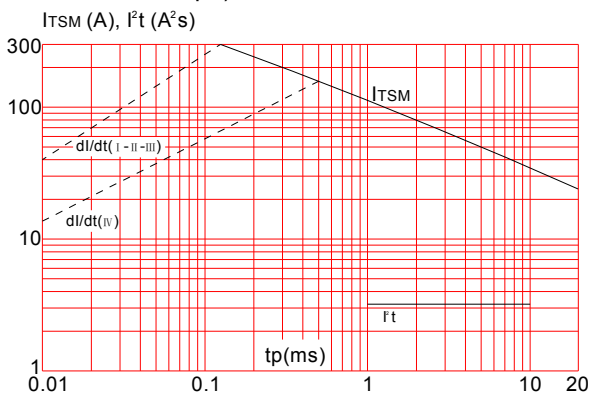

**FIG.2:** RMS on-state current versus case temperature

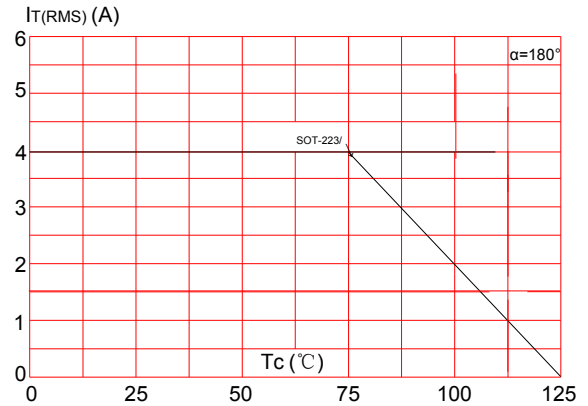

**FIG.4:** On-state characteristics (maximum values)

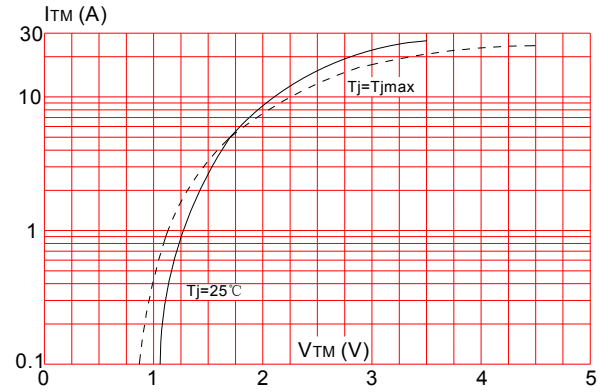

**FIG.6:** Relative variations of gate trigger current versus junction temperature

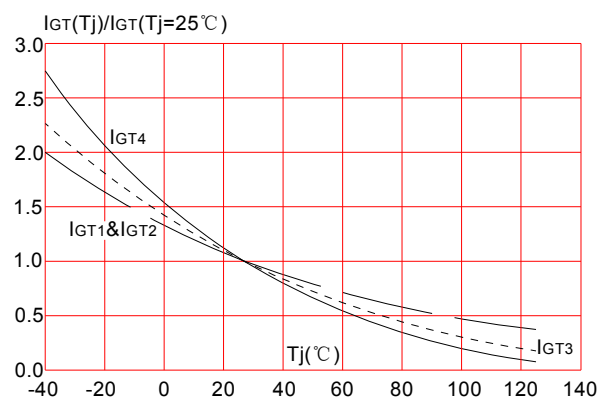

**FIG.7:** Relative variations of holding current versus junction temperature

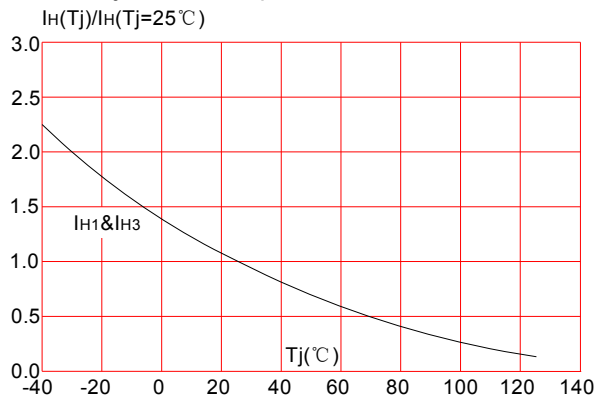

**FIG.8:** Relative variations of latching current versus junction temperature

