

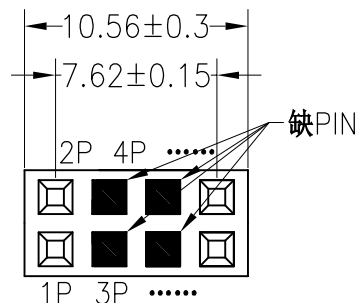

SPECIFICATIONS

Rated Current:3.0AMP
 Contact Resistance:20mΩ Max
 Withstand Voltage:1000V AC/DC
 Insulation Resistance:1000MΩ Min
 Operation Temperature:-40°C to +105°C

Contact Material:Brass
 Contact Plating:Au Over Ni
 Insulator Material:Polyester(UL94V-0)
 Standard: PA6T
 Max.Processing Temp: 230°C for 30-60 seconds
 (260°C for 10 seconds)



Recommended P.C.B Layout(Top Side)
 (PCB BOARD TOLERANCE±0.05)

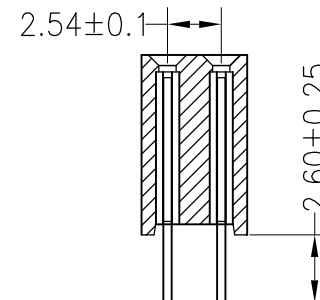
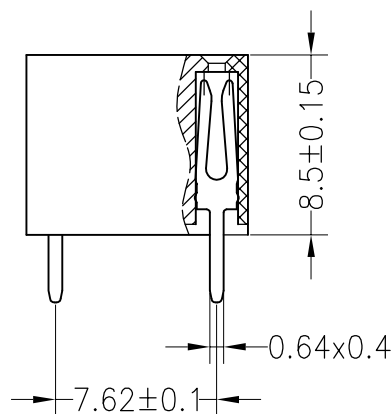
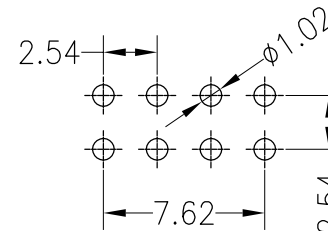

				OPERATION		DRAW		SCALE	FIT	深圳市连盛精密连接器有限公司	
				X.X	±0.30			UNIT	mm		
				X.XX	±0.20	CHECK		SIZE	A4	PART NO. FH-00065	
				X.XXX	±0.10			SHEET	1/1	TITLE: 2.54FH H8.5 2x4pin DIP W5.0 PC2.6 空2.3排	
				Angle	±3°	APPROVE		PROJ.	☐		
				DIM	TOL						
REV	DATE	MODIFICATION DESCRIPTION	CHANGE								
1	2	3	4	5		6		7		8	