

RoHS

SPECIFICATIONS

Rated Current:3.0AMP
 Contact Resistance:20mΩ Max
 Withstand Voltage:1000V AC/DC
 Insulation Resistance:1000MΩ Min
 Operation Temperature:-40°C to +105°C

Contact Material:Brass
 Contact Plating:Au Over Ni
 Insulator Material:Polyester(UL94V-0)
 Standard: PA6T
 Max.Processing Temp: 230°C for 30-60 seconds
 (260°C for 10 seconds)

Recommended P.C.B Layout(Top Side)
 (PCB BOARD TOLERANCE±0.05)

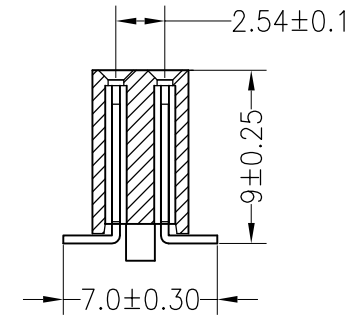
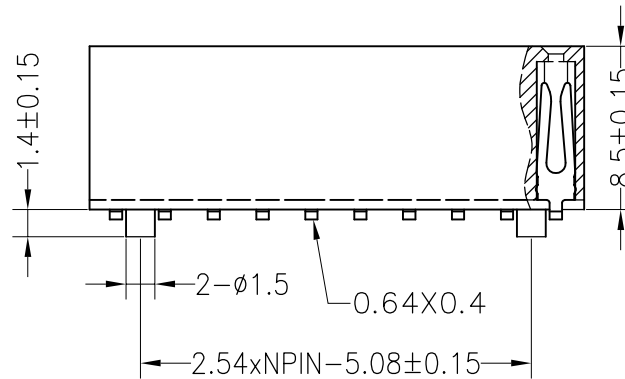
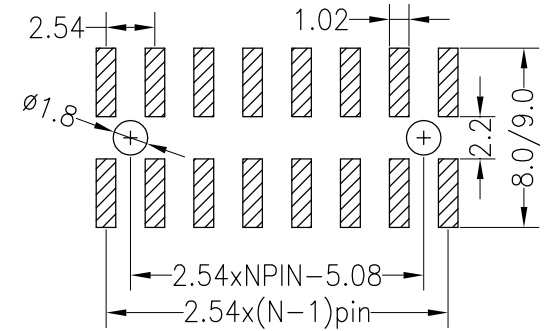
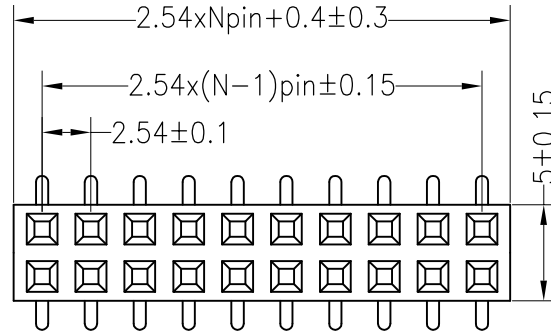

W= With Post

				OPERATION		DRAW		SCALE	FIT	深圳市连盛精密连接器有限公司		
				X.X	±0.30			UNIT	mm			
				CHECK				SIZE	A4	PART NO.		FH-00538
				APPROVE				SHEET	1/1	TITLE:		2.54FH H8.5mm 2x6pin SMT Y端
REV	DATE	MODIFICATION DESCRIPTION	CHANGE	DIM	TOL			PROJ.				