

# 規格承認書

## PECIFICATION FOR APPROVAL

客 戶  
CUSTOMER : \_\_\_\_\_  
項 目  
ITEM : 后进声硅微麦克风 (MEMS MIC)  
型 號  
TYPE : GMA3730H11-B38  
描述  
DESCRIPTION : L3.76 x W3.0xH1.1 mm -38 dB S/N: ≥58 dBA  
客戶料號  
CUSTOMER NO. : \_\_\_\_\_  
規 格 書 號  
SPECIFICATION NO.: \_\_\_\_\_  
版 本  
EDITION NO. : V1.0  
日 期  
DATE : 2020-2-26

### 客戶承認

#### CUSTOMER CONFIRM AND SIGN

檢 查 TESTED BY	審 核 CHECKED BY	承 認 APPROVED BY

### 東莞市贏海電子有限公司

#### DONGUAN INGHAI ELECTRONICS CO.,LTD

製 作 ISSUED BY	審 查 CHECKED BY	確 認 APPROVED BY
周明	刘承成	

地址：广东省东莞市长安镇上沙第五工业区新春路 1 号新春科技园

電話 / TEL: 0769-83060958 傳真 / FAX: 0769-81608993

網址: [HTTP://WWW.INGHAI.COM](http://www.inghai.com)

## A. GENERAL DESCRIPTION

GMA3730H11-B42 is a Silicon Microphone with analog output and bottom inlet for sound input. It is a cost-effective alternative to traditional electret condenser microphone(ECM). Provided on tap-and-reel, it is ideally suited for high volume applications. And it can be processed directly to customer's PCB using standard automatic pick-and-place equipment and surface mounted via standard solder reflow equipment..

## B. ABSOLUTE MAXIMUM RATINGS

Supply voltage :VDD to GND.....-0.3V~5V

ESD Tolerance

The Lid Mode.....8kV

The I/O Pin Mode.....4kV

TEMPERATURE CHARACTERISTICS					
Parameter	Conditions	Min	Typ	Max	Unit
Operating Temperature		-40		+85	°C
Storage Temperature	Solder on PC board	-40		+105	°C
	In Tape and Reel	-10		+50	°C

## C. ACOUSTIC & ELECTRICAL SPECIFICATIONS

Unless otherwise specified, test conditions are: Supply voltage  $V_{DD} = 2.2V$  Input sound pressure  $P_{IN} = 94dB$

SPL@1kHz Test room temperature  $T_a = 25^{\circ}C$ , Room Humidity = 50% A-weighting filter applied for noise floor measurement

PERFORMANCE					
Parameter	Conditions	Min	Typ	Max	Unit
Directivity		Omni-Directional			
Sensitivity	@1KHz (0 dB = 1V/Pa)	-41	-38	-35	dB
Signal-to-Noise Ratio	@1KHz (0 dB = 1V/Pa)		62		dB
Total Harmonic Distortion (THD) @ 100dB SPL	@1KHz		0.2	0.5	%
Total Harmonic Distortion (THD) @ 115dB SPL	@1KHz		0.5	1	%
Max Input Sound Pressure	@1KHz, THD < 10%		130		dB SPL
Power Supply Rejection (PSR)	217Hz, 100m Vpp square wave		-84	-79	dB

INPUT CHARACTERISTICS					
Power supply Voltage		1.6		3.6	V
Sensitivity Loss Across Power Supply Voltage	Change in sensitivity from 1.6V to 3.6V power supply voltage	No change			dB
Total Operation Current	1.6V-3.6V power supply voltage		160	200	uA
Standby Current	1.6V-3.6V power supply voltage			2	uA
OUTPUT CHARACTERISTICS					
LOAD Capacitance				100	pF
Output Impedance	@1KHz (0 dB = 1 V/Pa)			200	$\Omega$

#### D. FREQUENCY RESPONSE CURVE

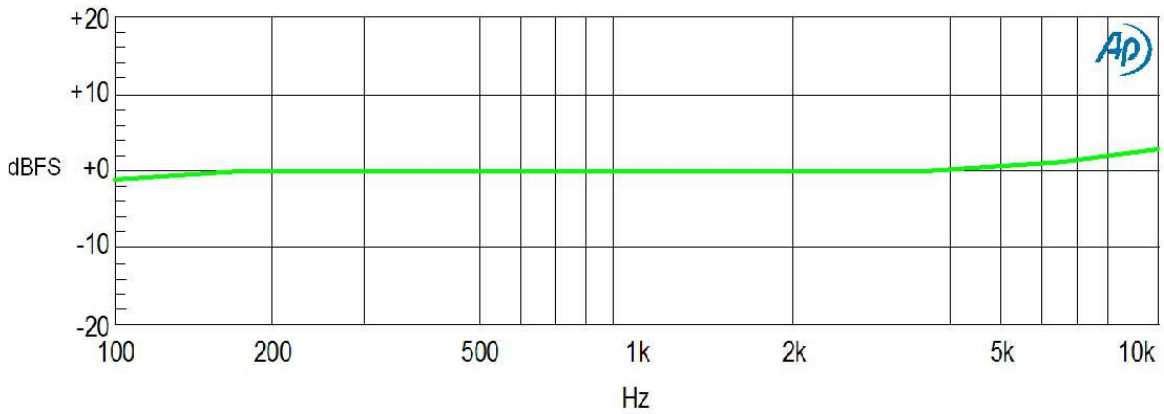

. Typical free field frequency response (Normalized to 1 KHz)

#### E.MECHANICAL SPECIFIONS

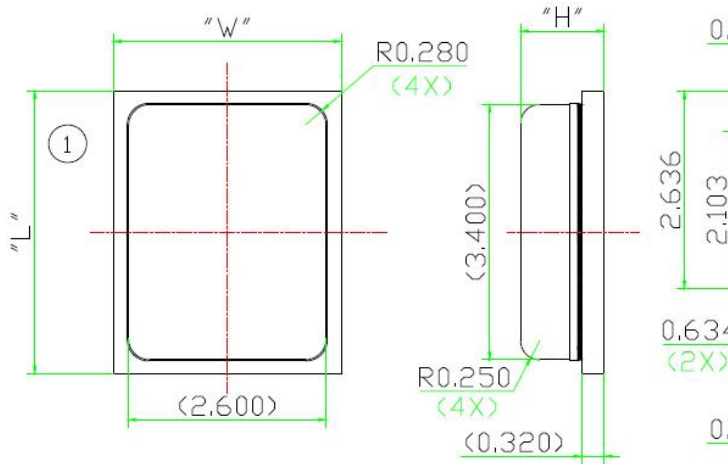

ITEM	DIMENSION	TOLERANCE	UNITS
LENGTH(L)	3.76	±0.10	mm
WIDTH(W)	3.00	±0.10	mm
HEIGHT(H)	1.10	±0.10	mm
ACOUSTIC PORT(AP)	Φ0.25	±0.05	mm

PIN OUTPUT	
PIN#	FUNCTION
1	OUTPUT
2	GROUND
3	GROUND
4	POWER(Vdd)
5	GROUND
6	GROUND

Dimensions are in millimetre unless otherwise specified.

Tolerance ±0.15mm unless otherwise specified Figure 2. Detailed mechanical drawings

## F.RECOMMENDED CUSTOMER LANDING PATTERN

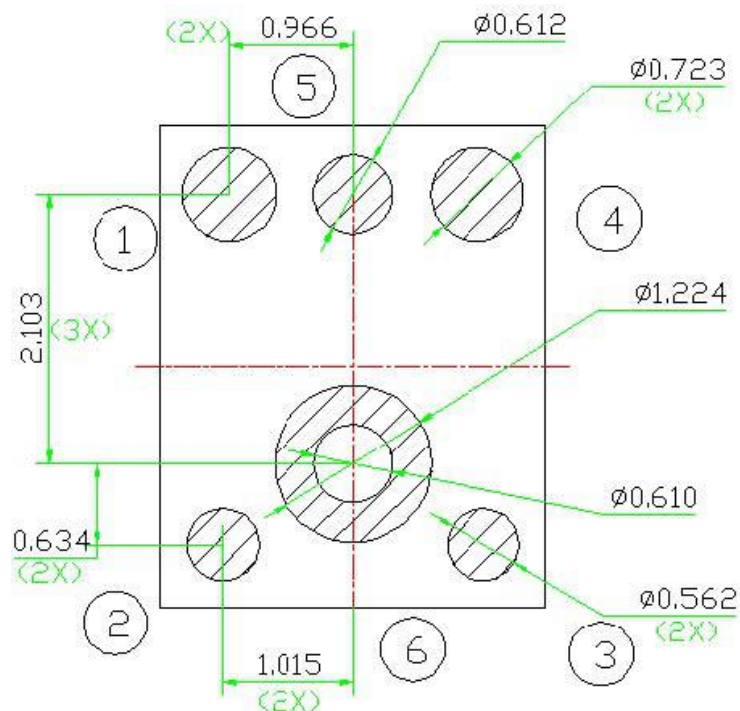

Recommended landing pattern on customer 's PCB

## G. RECOMMENDED INTERFACE CIRCUIT

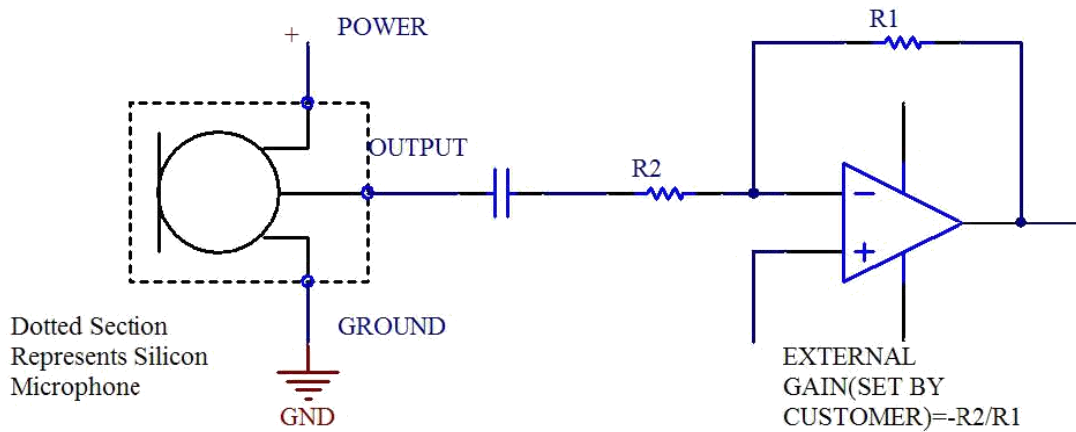

. Recommended interface circuit for customers' applications

## H. PACKAGING SPECIFICATIONS

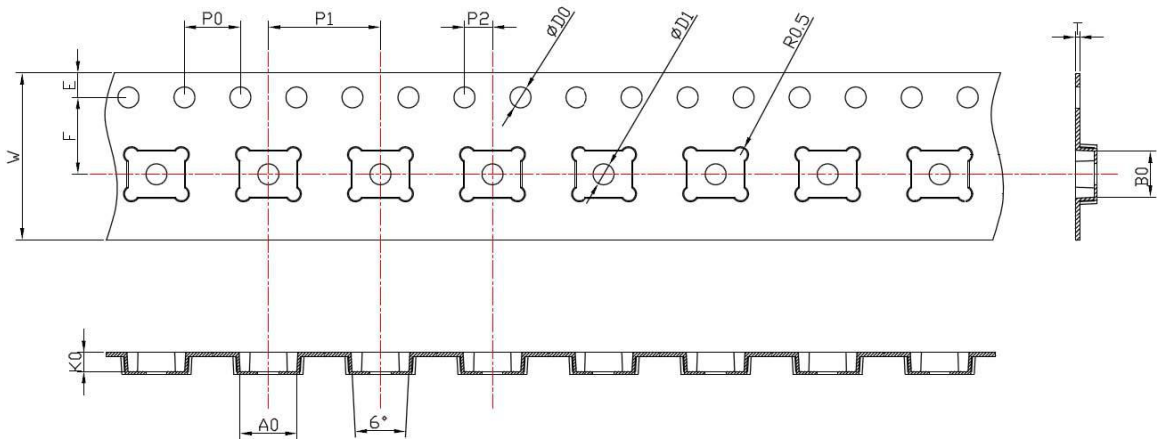

D0	$1.5 \pm 0.1$	W	$12.0 \pm 0.30$
D1	$1.5 \pm 0.1$	E	$1.75 \pm 0.10$
A0	$4.06 \pm 0.10$	F	$5.50 \pm 0.10$
B0	$3.30 \pm 0.10$	P0	$4.00 \pm 0.10$
K0	$1.35 \pm 0.10$	P1	$8.00 \pm 0.10$
T	$0.3 \pm 0.05$	P2	$2.00 \pm 0.10$

Notes:

- (1) Tape & Reel Per EIA-481 standard;
- (2) Label applied to external package and direct to reel

Order Part Number	Reel Diameter	Qty per Reel
GMA3730H11-B42	13"	5,000

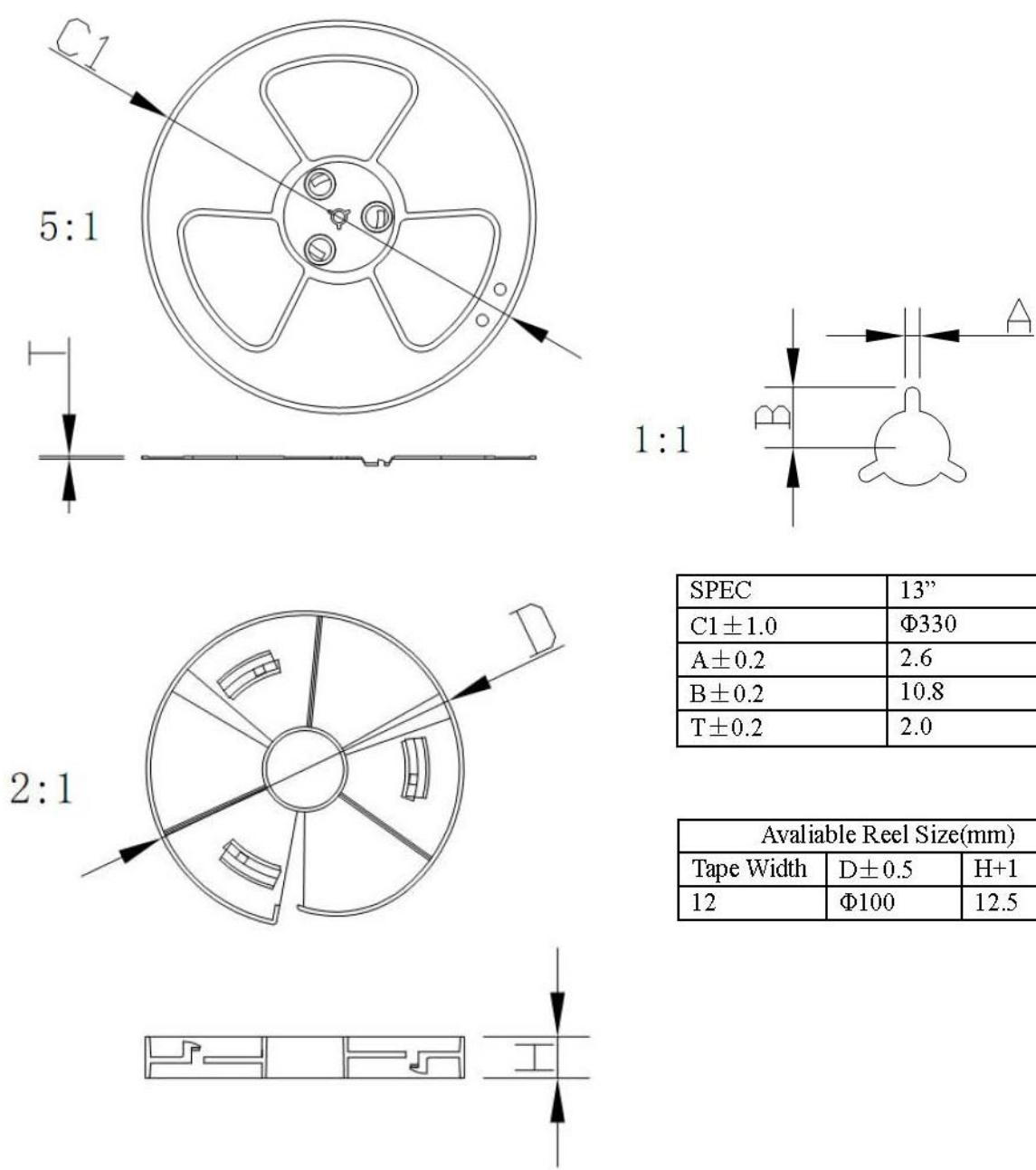

SPEC	13"
$C1 \pm 1.0$	$\Phi 330$
$A \pm 0.2$	2.6
$B \pm 0.2$	10.8
$T \pm 0.2$	2.0

Avaliable Reel Size(mm)		
Tape Width	$D \pm 0.5$	$H+1$
12	$\Phi 100$	12.5

5,000PCS PRODUCTS/1 reel

Figure 6. Reel Specification 5,000PCS PRODUCTS/1 reel

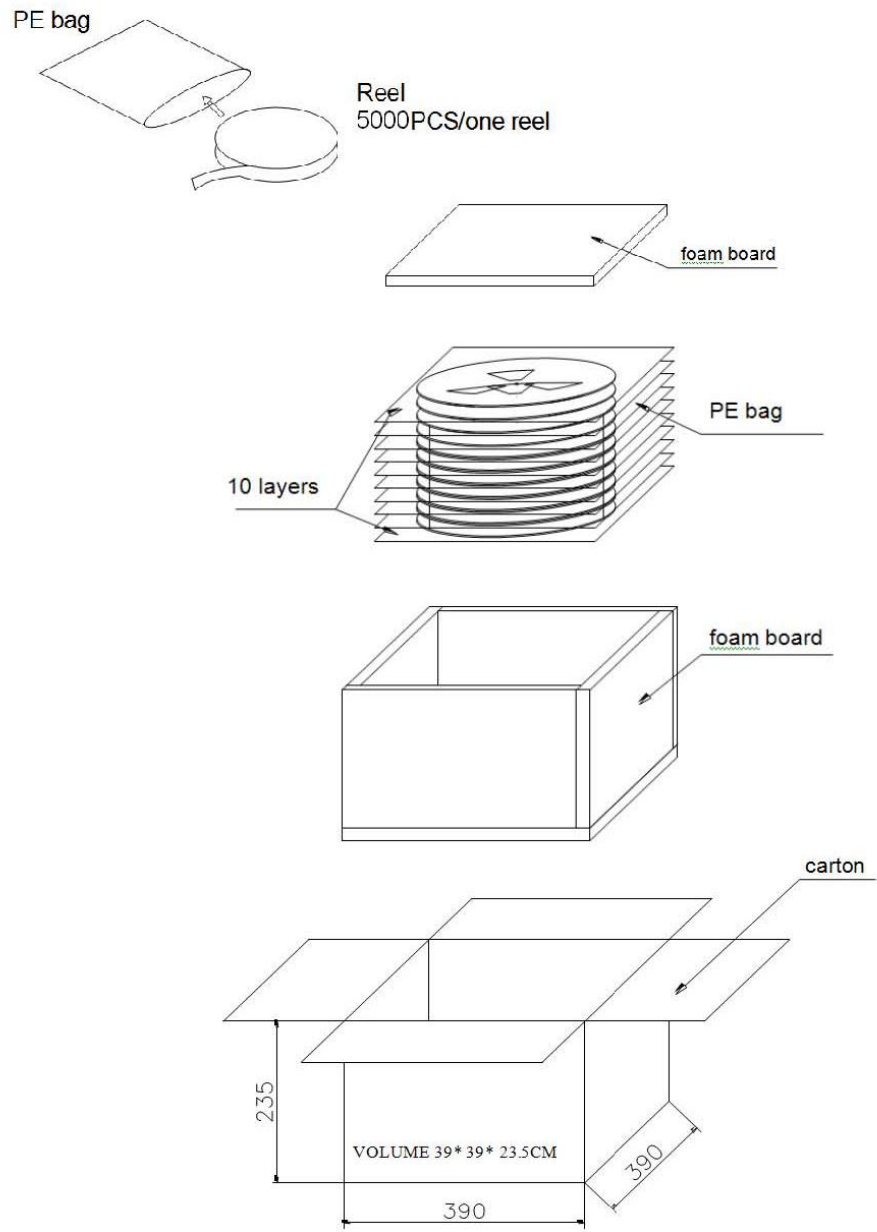

50,000 Pieces of Products per Carton

# I. RECOMMENDED REFLOW PROFILE

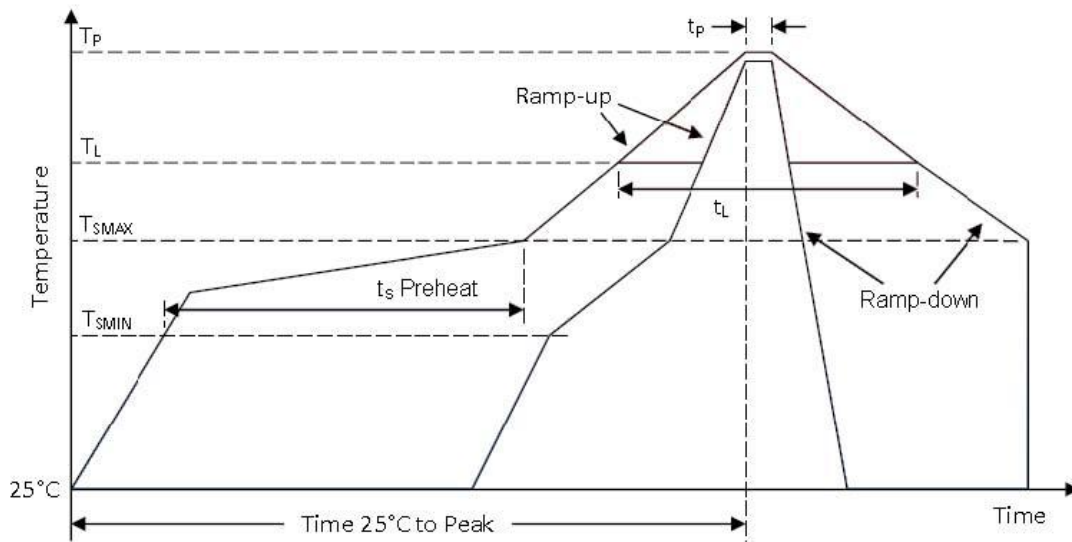

Profile Feature	Pb-Free
Average Ramp-up rate (T <sub>S</sub> MAX to T <sub>P</sub> )	3°C/second max.
Preheat Temperature Min (T <sub>S</sub> MIN) Temperature Max (T <sub>S</sub> MAX) Time (T <sub>S</sub> MIN to T <sub>S</sub> MAX) (t <sub>s</sub> )	150°C 200°C 60-180 seconds
Time maintained above: Temperature (T <sub>L</sub> ) Time (t <sub>L</sub> )	217°C 60-150 seconds
Peak Temperature (T <sub>P</sub> )	260°C
Time within 5°C of actual Peak Temperature (t <sub>p</sub> )	20-40 seconds
Ramp-down rate(T <sub>P</sub> to T <sub>S</sub> MAX)	6°C/second max
Time 25°C to Peak Temperature	8 minutes max

Notes:

1. Vacuuming over acoustical hole of the microphone is not allowed, because the device can be damaged by vacuum.
2. To wash the board after reflow process is not allowed, because board washing and Cleaning agents can damage the device. A device should not be exposed to ultrasonic processing or cleaning.
3. Recommended number of reflow is no more than 5 Times.



## N. RELIABILITY SPECIFICATIONS

Test item	Detail	standard
Reflow Simulation	Refer to Sec.9 for solder reflow profile, total 5 times	/
Low Temperature Bias	Conditions:-40°C Duration:168 hours while under bias	IEC 60068-2-2 Test Aa
High Temperature Bias	Conditions: 105°C Duration:168 hours while under bias	IEC 60068-2-2 Test Ba
Thermal Shock	Conditions: 100 cycles of air-air thermal shock from -40 °C to 125 °C with 15-minute soaks	IEC 60068-2-4
Temperature/Humidity Bias	Conditions: 85 °C /85%RH environment while under bias for 168 hours	JESD 22-A101A-B
Mechanical Shock	Conditions:3 pulses of 10,000g in the X,Y and Z direction	JEC 60068-2-27 Test Ea
Vibration Test	Test axis: X,Y,Z Conditions:2~400Hz 1 oct/min Test time:15mins per axis Use fixture during the testing	IEC 60068-2-6
Drop Test	Conditions: 1.8-meter height onto a concrete surface each time at three directions in state of packaging	IEC 60068-2-32
ESD	Conditions: ±8KV direct contact to the lid when unit is grounded, ±4KV direct contact to the I/O pins. 10 times	IEC 61000-4-2

Note: Immediately after reliability test, the samples shall be stored under climatic conditions such as that normally exists in ordinary rooms or laboratories. Unless otherwise noted , the recovery period shall be 2 hours at least before performance testing. After test condition is performed, the sensitivity of the microphone shall not deviate more than 3dB from its initial value.