

REV.	DESCRIPTION	NAME	DATE
A	NEWS ISSUE		

NOTE:

- MATERIAL:
 - INSULATOR: HIGH TEMPERATURE PLASTIC UL 94 V-0;
 - CONTACT: COPPER ALLOY
 - SHELL: STAINLESS STEEL
- ELECTRICAL CHARACTERISTICS:
 - CONTACT RESISTANCE: 40mΩ Max FOR INITIAL, 10mΩ CHANGE AFTER TEST, MEASURE AT 20mV, 100mA.
 - CONTACT CURRENT RATING: 3A FOR VBUS PIN, 1.25A FOR VCONN PIN.
 - DIELECTRIC WITHSTANDING VOLTAGE: 100V AC R.M.S.
 - INSULATION RESISTANCE 100MΩ Min
 - OPERATING TEMPERATURE: -40°C ~ 85°C
- MECHANICAL CHARACTERISTICS:
 - MATING FORCE: 5~20 N.
 - UNMATED FORCE: 6~20N AFTER TEST
 - DURABILITY: 10,000 CYCLES
- PLATING
 - TERMINAL CONTACT: (SEE TAB) GOLD PLATING ALL OVER 50u" NICKEL AND 80u" Tin ALL OVER 50u" NICKEL ON SOLDER AREA
 - SHELL: 50u" NICKEL ALL OVER,

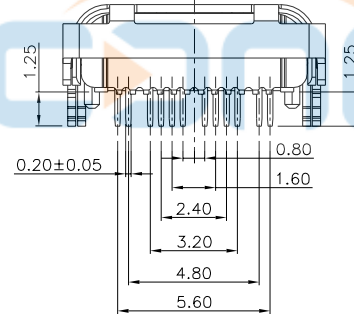
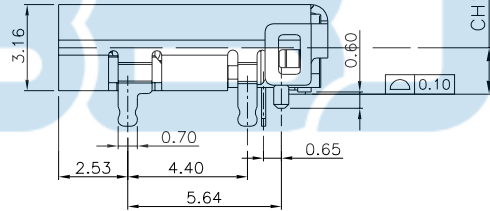
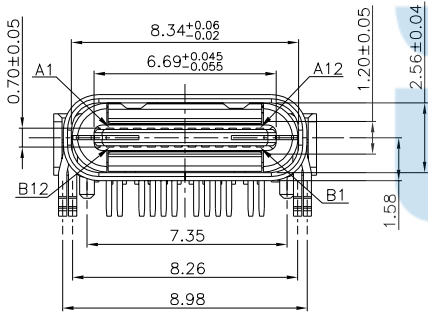

PIN	SIGNAL NAME	PIN	SIGNAL NAME
A1	GND	B12	GND
A2	TX1+	B11	RX1+
A3	TX1-	B10	RX1-
A4	VBUS	B9	VBUS
A5	CC1	B8	SBU2
A6	D+	B7	D-
A7	D-	B6	D+
A8	SBU1	B5	CC2
A9	VBUS	B4	VBUS
A10	RX2-	B3	TX2-
A11	RX2+	B2	TX2+
A12	GND	B1	GND

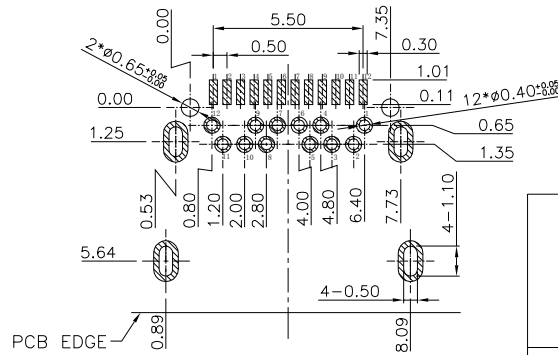
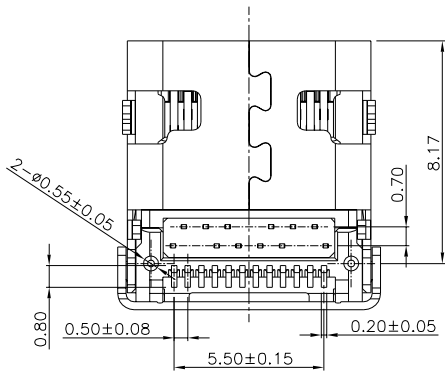

RECOMMEND PCB LAYOUT(TOLERANCE:±0.05)
(THICKNESS:1.0mm OR 1.2mm)

TOLERANCE UNSPECIFIED	
.0	±0.3
.00	±0.2
.0000	±0.1
.0°	±1.0°
.00°	±0.5°
.000°	±0.2°

深圳市步步精科技有限公司

TITLE: USB 3.1 C TYPE 24P 母座 板上 L=9.8mm 排距 0.70mm 外壳后盖掬料 脚长1.25mm CH1.71

DRAWN/ DATE	设计 HMY	SIZE:A4	UNIT:MM.	PART. NO:	UC. 01. 52-1F-0002
CHECKED/ DATE	审核 LYX	SCALE: 1:1	PROJECTION	REV. : 版本	
APPROVED/ DATE	核准 LJP	DWG. PATH	0299-2		SHEET: 页码

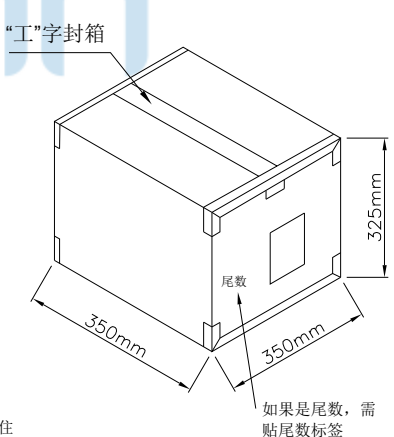
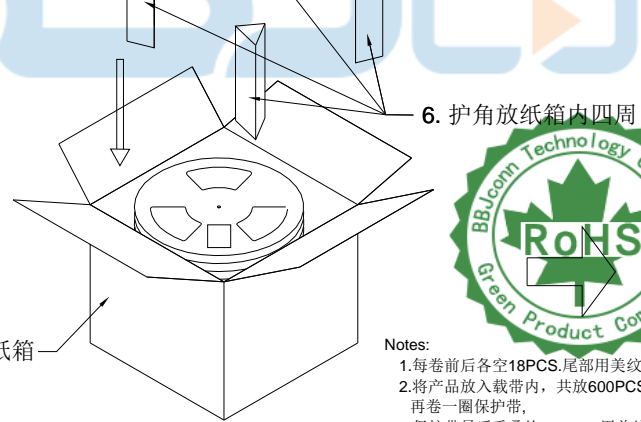
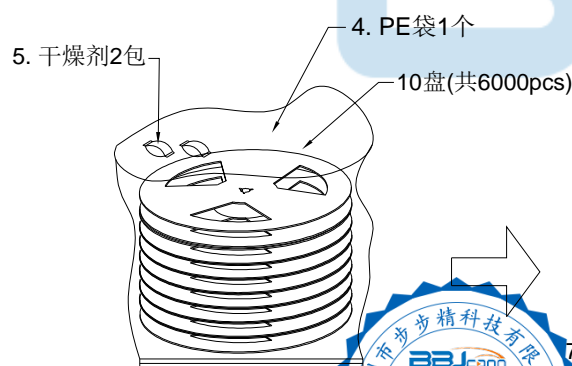
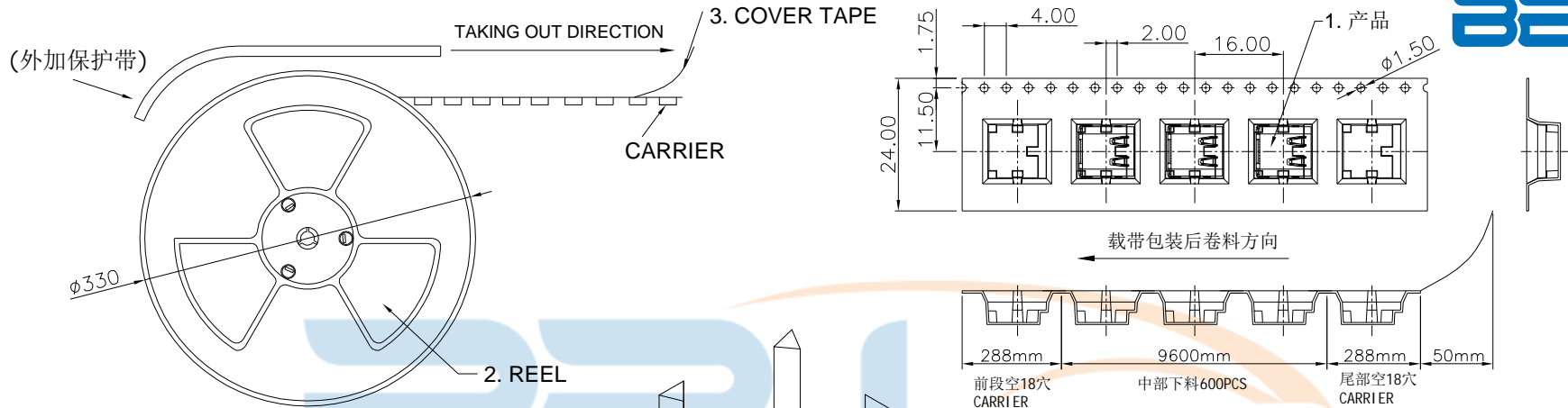

- Notes:
1. 每卷前后各空18PCS. 尾部用美纹胶纸封住,
 2. 将产品放入载带内, 共放600PCS, 放满盘后, 再卷一圈保护带, 保护带最后重叠约50mm, 用美纹胶纸将其封住,
 3. 每10卷盘装入一个防水袋, 再放入2包干燥剂, 然后放入1个外箱内; 纸箱内四周放护角;
 4. 在搬运过程中要轻拿轻放.
 5. 在运输中不可堆放过多, 不可有重压现象.

6. 跌落测试条件:
成品箱子从1.5米高自由落体(三棱六面一角)检验项目:
1. 产品不可跑出下带凹槽.
 2. 产品不可有摔伤, 变形.
 3. 外箱及内包装材料不可严重破损.

7	纸箱	PA-001Z	双坑K=K 350*350*325mm	1PCS
6	三角柱	PB-001Z	30.5*29cm	4PCS
5	干燥剂	F001	—	2PCS
4	PE袋	PE-001Z	71*79.5cm	1PCS
3	COVER TAPE	PC-004W	21.0mm (自粘带)	若干
2	REEL	PR-004Z	24.0mm (黑色载带)	10R
1	产品	A18F2405-XXXRZ	—	6K
序号	品名	料号	规格(mm)	用量(PCS)

包装数量	净重	毛重
6000Pcs/箱		

TOLERANCE UNSPECIFIED		深圳市步步精科技有限公司			
.0	±0.40				
.00	±0.25	TITLE: USB 3.1 C TYPE 24P 母座 板上 L=9.8mm 排距 0.70mm 外壳后盖掏料 脚长1.25mm CH1.71			
.000	±0.15	SIZE: A4	UNIT: MM	PART. NO: UC. 01. 52-1F-0002	
X. °	±0.3°	CHECKED/ DATE	设计 HMY	SCALE: 1:1	PROJECTION
CUSTOMER DRAWING		APPROVED/ DATE	审核 LYX	DWG. PATH	REV.: 版本
			核准 LJP	0299-2	SHEET: 页码