

1 Features

- Wide Input Voltage Range: 3 V to 40 V
- High Output Switch Current: Up to 1.5 A
- Adjustable Output Voltage
- Oscillator Frequency Up to 100 kHz
- Precision Internal Reference: 2%
- Short-Circuit Current Limiting
- Low Standby Current

2 Applications

- Blood Gas Analyzers: Portable
- Cable Solutions
- HMIs (Human Machine Interfaces)
- Telecommunications
- Portable Devices
- Consumer & Computing
- Test & Measurement

3 Description

The XD34063 and XD33063 devices are easy-to-use ICs containing all the primary circuitry needed for building simple DC-DC converters. These devices primarily consist of an internal temperature-compensated reference, a comparator, an oscillator, a PWM controller with active current limiting, a driver, and a high-current output switch. Thus, the devices require minimal external components to build converters in the boost, buck, and inverting topologies.

The XD34063 device is characterized for operation from -40°C to 85°C , while the XD33063 device is characterized for operation from 0°C to 70°C .

5 Device Information⁽¹⁾

PART NUMBER	PACKAGE (PIN)	BODY SIZE
33063 /34063	SOIC (8)	4.90 mm x 3.91 mm
	SON (8)	4.00 mm x 4.00 mm
	PDIP (8)	9.81 mm x 6.35 mm

(1) For all available packages, see the orderable addendum at the end of the data sheet.

4 Simplified Schematic

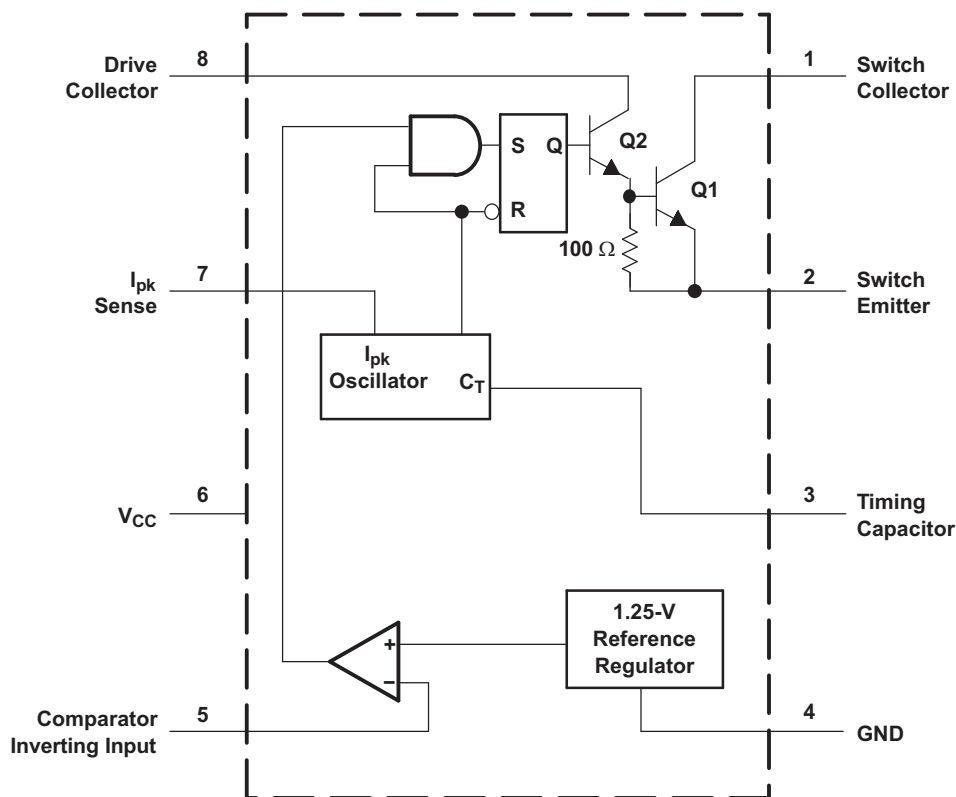

6 Pin Configuration and Functions

**D (SOIC) OR P (PDIP) PACKAGE
(TOP VIEW)**

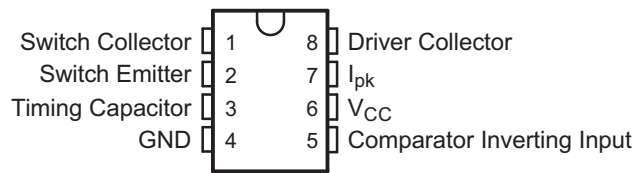

**DRJ (QFN) PACKAGE
(TOP VIEW)**

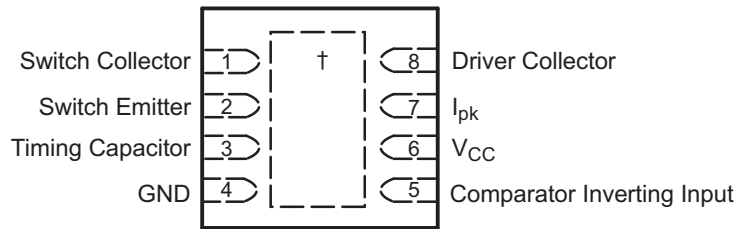

† The exposed thermal pad is electrically bonded internally to pin 4 (GND) .

Pin Functions

PIN		TYPE	DESCRIPTION
NAME	NO.		
Switch Collector	1	I/O	High-current internal switch collector input.
Switch Emitter	2	I/O	High-current internal switch emitter output.
Timing Capacitor	3	—	Attach a timing capacitor to change the switching frequency.
GND	4	—	Ground
Comparator Inverting Input	5	I	Attach to a resistor divider network to create a feedback loop.
V_{CC}	6	I	Logic supply voltage. Tie to V_{IN} .
I_{PK}	7	I	Current-limit sense input.
Driver Collector	8	I/O	Darlington pair driving transistor collector input.

XD34063 DIP8/XD33063 DIP8–XL34063 SOP8/XL33063 SOP8

7 Specifications

7.1 Absolute Maximum Ratings

over operating free-air temperature range (unless otherwise noted)⁽¹⁾

		MIN	MAX	UNIT
V _{CC}	Supply voltage		40	V
V _{IR}	Comparator inverting input voltage range	–0.3	40	V
V _{C(switch)}	Switch collector voltage		40	V
V _{E(switch)}	Switch emitter voltage		40	V
		V _{PIN1} = 40 V		
V _{CE(switch)}	Switch collector to switch emitter voltage		40	V
V _{C(driver)}	Driver collector voltage		40	V
I _{C(driver)}	Driver collector current		100	mA
I _{SW}	Switch current		1.5	A
T _J	Operating virtual junction temperature		150	°C
T _{stg}	Storage temperature range	–65	150	°C

(1) Stresses beyond those listed under *Absolute Maximum Ratings* may cause permanent damage to the device. These are stress ratings only, and functional operation of the device at these or any other conditions beyond those indicated under *Recommended Operating Conditions* is not implied. Exposure to absolute-maximum-rated conditions for extended periods may affect device reliability.

7.2 ESD Ratings

		VALUE	UNIT
V _(ESD)	Electrostatic discharge	Human body model (HBM), per ANSI/ESDA/JEDEC JS-001, all pins ⁽¹⁾	2500
		Charged device model (CDM), per JEDEC specification JESD22-C101, all pins ⁽²⁾	1500
			V

(1) JEDEC document JEP155 states that 500-V HBM allows safe manufacturing with a standard ESD control process.

(2) JEDEC document JEP157 states that 250-V CDM allows safe manufacturing with a standard ESD control process.

7.3 Recommended Operating Conditions

		MIN	MAX	UNIT
V _{CC}	Supply voltage	3	40	V
T _A	Operating free-air temperature	XD34063	–40	85
		XD33063	0	70
			°C	

7.4 Thermal Information

THERMAL METRIC ⁽¹⁾	XD33063			UNIT	
	D	DRJ	P		
	8 PINS				
R _{θJA}	Junction-to-ambient thermal resistance	97	41	85	°C/W

(1) For more information about traditional and new thermal metrics, see the *IC Package Thermal Metrics* application report (SPRA953).

7.5 Electrical Characteristics—Oscillator

V_{CC} = 5 V, T_A = full operating range (unless otherwise noted) (see block diagram)

PARAMETER	TEST CONDITIONS	T _A	MIN	TYP	MAX	UNIT	
f _{osc}	Oscillator frequency	V _{PIN5} = 0 V, C _T = 1 nF	25°C	24	33	42	kHz
I _{chg}	Charge current	V _{CC} = 5 V to 40 V	25°C	24	35	42	μA
I _{dischg}	Discharge current	V _{CC} = 5 V to 40 V	25°C	140	220	260	μA
I _{dischg} /I _{chg}	Discharge-to-charge current ratio	V _{PIN7} = V _{CC}	25°C	5.2	6.5	7.5	—
V _{lpk}	Current-limit sense voltage	I _{dischg} = I _{chg}	25°C	250	300	350	mV

XD34063 DIP8/XD33063 DIP8–XL34063 SOP8/XL33063 SOP8

7.6 Electrical Characteristics—Output Switch

$V_{CC} = 5\text{ V}$, $T_A =$ full operating range (unless otherwise noted) (see block diagram)⁽¹⁾

PARAMETER		TEST CONDITIONS	T_A	MIN	TYP	MAX	UNIT
$V_{CE(sat)}$	Saturation voltage – Darlington connection	$I_{SW} = 1\text{ A}$, pins 1 and 8 connected	Full range		1	1.3	V
$V_{CE(sat)}$	Saturation voltage – non-Darlington connection ⁽²⁾	$I_{SW} = 1\text{ A}$, $R_{PIN8} = 82\ \Omega$ to V_{CC} , forced $\beta \sim 20$	Full range		0.45	0.7	V
h_{FE}	DC current gain	$I_{SW} = 1\text{ A}$, $V_{CE} = 5\text{ V}$	25°C	50	75		—
$I_{C(off)}$	Collector off-state current	$V_{CE} = 40\text{ V}$	Full range		0.01	100	μA

(1) Low duty-cycle pulse testing is used to maintain junction temperature as close to ambient temperature as possible.

(2) In the non-Darlington configuration, if the output switch is driven into hard saturation at low switch currents ($\leq 300\text{ mA}$) and high driver currents ($\geq 30\text{ mA}$), it may take up to $2\ \mu\text{s}$ for the switch to come out of saturation. This condition effectively shortens the off time at frequencies $\geq 30\text{ kHz}$, becoming magnified as temperature increases. The following output drive condition is recommended in the non-Darlington configuration:

Forced β of output switch = $I_{C,SW} / (I_{C,driver} - 7\text{ mA}) \geq 10$, where $\sim 7\text{ mA}$ is required by the $100\text{-}\Omega$ resistor in the emitter of the driver to forward bias the V_{be} of the switch.

7.7 Electrical Characteristics—Comparator

$V_{CC} = 5\text{ V}$, $T_A =$ full operating range (unless otherwise noted) (see block diagram)

PARAMETER		TEST CONDITIONS	T_A	MIN	TYP	MAX	UNIT
V_{th}	Threshold voltage		25°C	1.225	1.25	1.275	V
			Full range	1.21		1.29	
ΔV_{th}	Threshold-voltage line regulation	$V_{CC} = 5\text{ V to } 40\text{ V}$	Full range		1.4	5	mV
I_{IB}	Input bias current	$V_{IN} = 0\text{ V}$	Full range		-20	-400	nA

7.8 Electrical Characteristics—Total Device

$V_{CC} = 5\text{ V}$, $T_A =$ full operating range (unless otherwise noted) (see block diagram)

PARAMETER		TEST CONDITIONS	T_A	MIN	MAX	UNIT
I_{CC}	Supply current	$V_{CC} = 5\text{ V to } 40\text{ V}$, $C_T = 1\text{ nF}$, $V_{PIN7} = V_{CC}$, $V_{PIN5} > V_{th}$, $V_{PIN2} = \text{GND}$, All other pins open	Full range		4	mA

7.9 Typical Characteristics

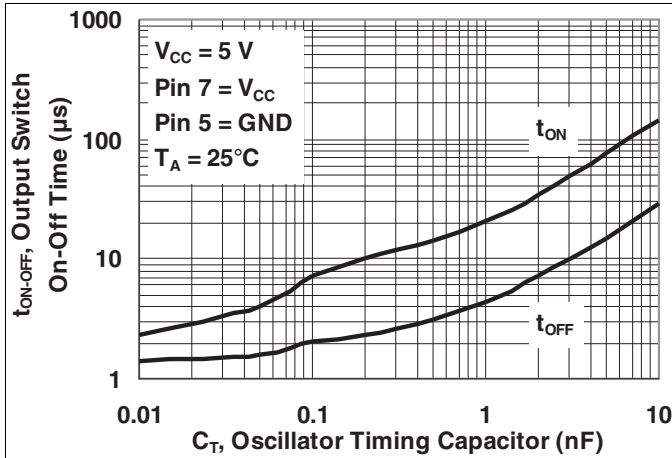

Figure 1. Output Switch On-Off Time vs Oscillator Timing Capacitor

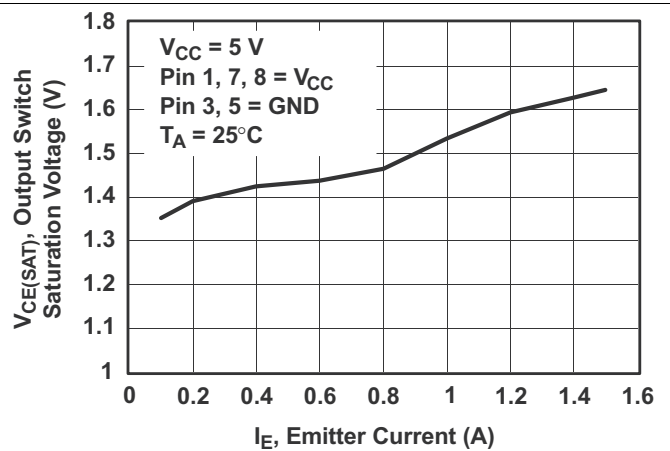

Figure 2. Output Switch Saturation Voltage vs Emitter Current (Emitter-Follower Configuration)

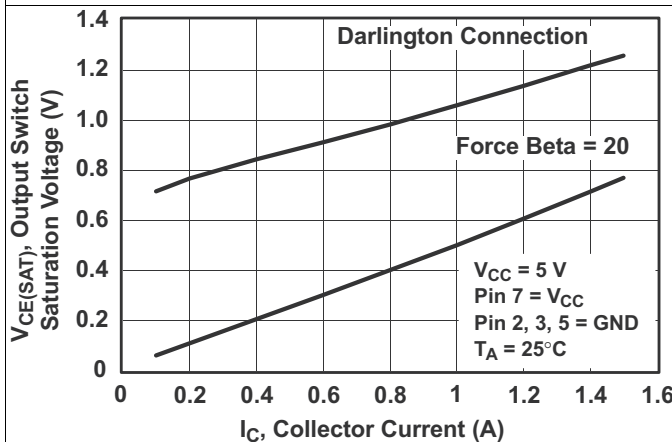

Figure 3. Output Switch Saturation Voltage vs Collector Current (Common-Emitter Configuration)

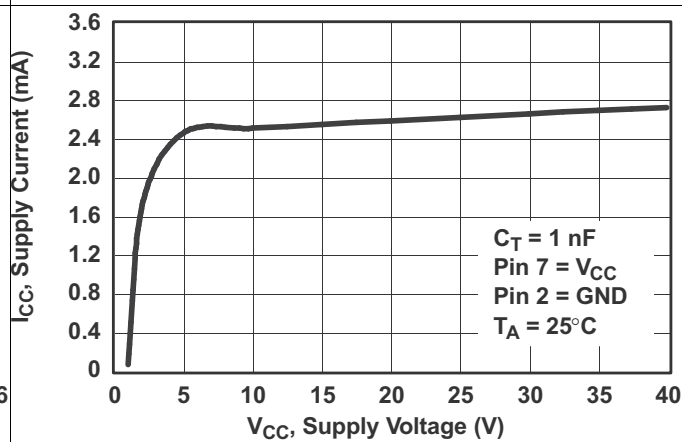

Figure 4. Standby Supply Current vs Supply Voltage

8 Detailed Description

8.1 Overview

The XD33063 and XD34063 devices are easy-to-use ICs containing all the primary circuitry needed for building simple DC-DC converters. These devices primarily consist of an internal temperature-compensated reference, a comparator, an oscillator, a PWM controller with active current limiting, a driver, and a high-current output switch. Thus, the devices require minimal external components to build converters in the boost, buck, and inverting topologies.

The XD33063 device is characterized for operation from -40°C to 85°C , while the XD34063 device is characterized for operation from 0°C to 70°C .

8.2 Functional Block Diagram

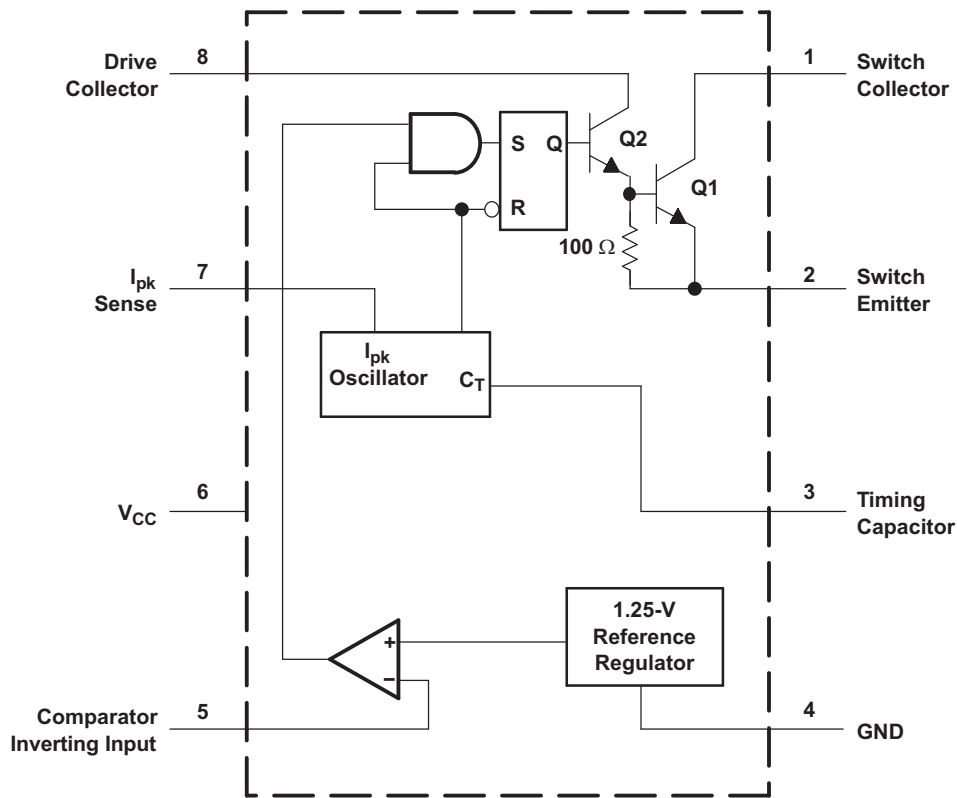

8.3 Feature Description

- Wide Input Voltage Range: 3 V to 40 V
- High Output Switch Current: Up to 1.5 A
- Adjustable Output Voltage
- Oscillator Frequency Up to 100 kHz
- Precision Internal Reference: 2%
- Short-Circuit Current Limiting
- Low Standby Current

8.4 Device Functional Modes

8.4.1 Standard operation

Based on the application, the device can be configured in multiple different topologies. See the *Application and Implementation* section for how to configure the device in several different operating modes.

9 Application and Implementation

9.1 Application Information

9.1.1 External Switch Configurations for Higher Peak Current

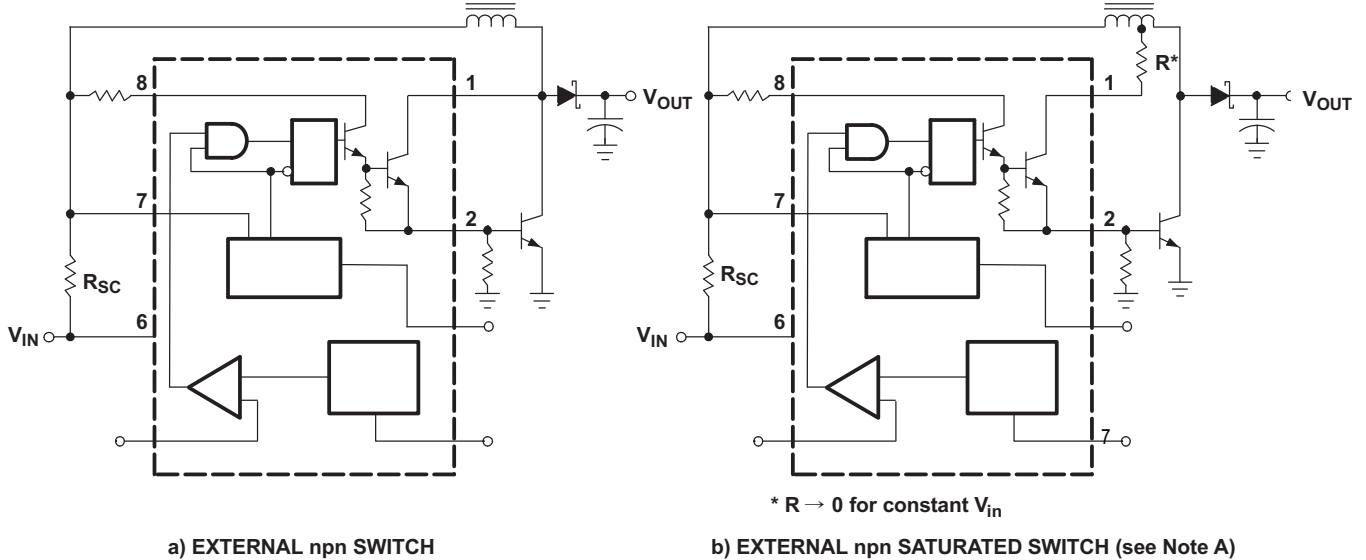

- A. If the output switch is driven into hard saturation (non-Darlington configuration) at low switch currents (≤ 300 mA) and high driver currents (≥ 30 mA), it may take up to $2 \mu\text{s}$ to come out of saturation. This condition will shorten the off time at frequencies ≥ 30 kHz and is magnified at high temperatures. This condition does not occur with a Darlington configuration because the output switch cannot saturate. If a non-Darlington configuration is used, the output drive configuration in Figure 7b is recommended.

Figure 5. Boost Regulator Connections for I_C Peak Greater Than 1.5 A

Application Information (continued)

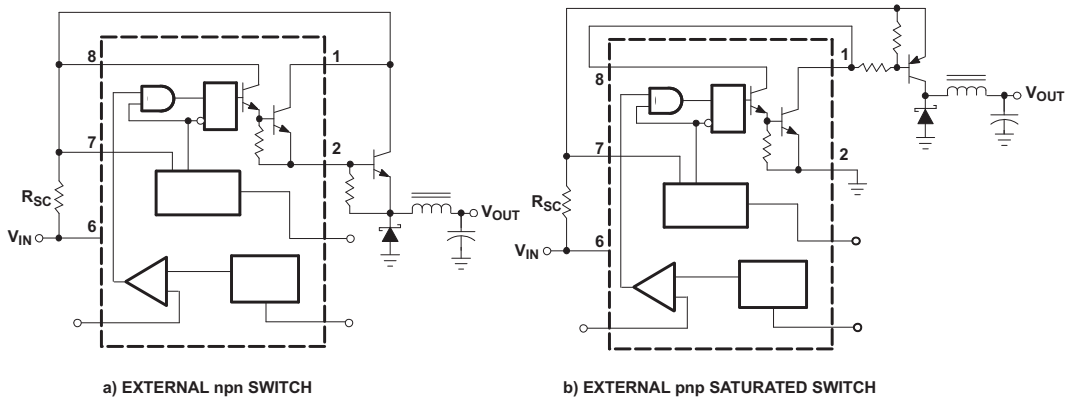

Figure 6. Buck Regulator Connections for I_C Peak Greater Than 1.5 A

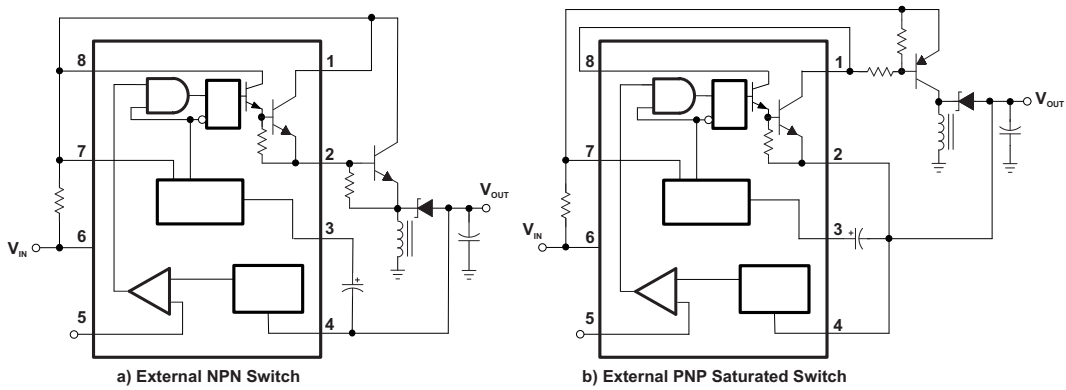
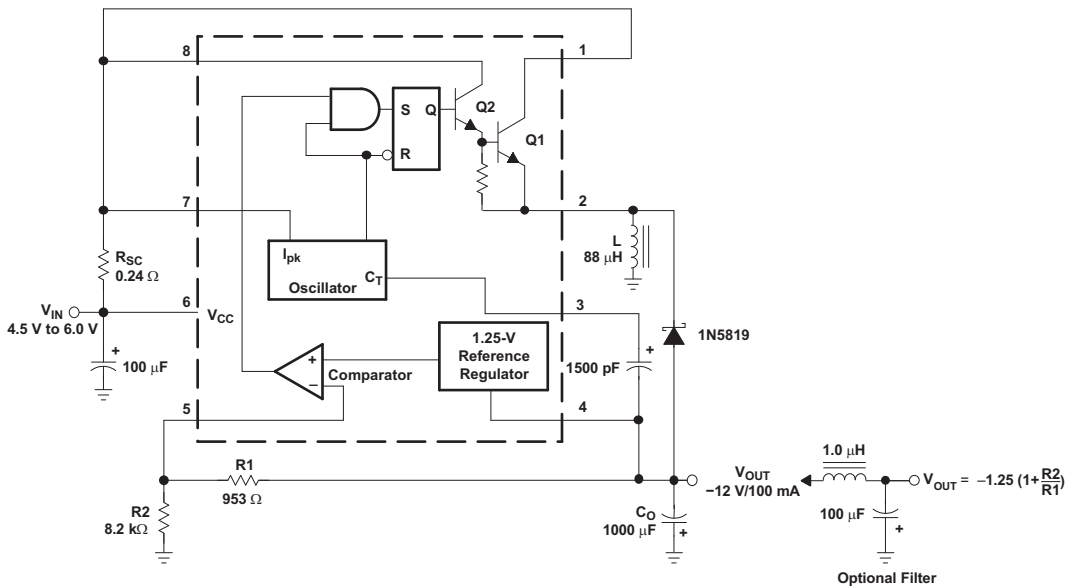

Figure 7. Inverting Regulator Connections for I_C Peak Greater Than 1.5 A

9.2 Typical Application

9.2.1 Voltage-Inverting Converter Application



Typical Application (continued)

9.2.1.1 Design Requirements

The user must determine the following desired parameters:

V_{sat} = Saturation voltage of the output switch

V_F = Forward voltage drop of the chosen output rectifier

The following power-supply parameters are set by the user:

V_{in} = Nominal input voltage

V_{out} = Desired output voltage

I_{out} = Desired output current

f_{min} = Minimum desired output switching frequency at the selected values of V_{in} and I_{out}

V_{ripple} = Desired peak-to-peak output ripple voltage. The ripple voltage directly affects the line and load regulation and, thus, must be considered. In practice, the actual capacitor value should be larger than the calculated value, to account for the capacitor's equivalent series resistance and board layout.

9.2.1.2 Detailed Design Procedure

CALCULATION	VOLTAGE INVERTING
t_{on}/t_{off}	$\frac{ V_{out} + V_F}{V_{in} - V_{sat}}$
$(t_{on} + t_{off})$	$\frac{1}{f}$
t_{off}	$\frac{t_{on} + t_{off}}{\frac{t_{on}}{t_{off}} + 1}$
t_{on}	$(t_{on} + t_{off}) - t_{off}$
C_T	$4 \times 10^{-5} t_{on}$
$I_{pk(switch)}$	$2I_{out(max)} \left(\frac{t_{on}}{t_{off}} + 1 \right)$
R_{SC}	$\frac{0.3}{I_{pk(switch)}}$
$L_{(min)}$	$\left(\frac{(V_{in(min)} - V_{sat})}{I_{pk(switch)}} \right) t_{on(max)}$
C_O	$9 \frac{I_{out} t_{on}}{V_{ripple(pp)}}$
V_{out}	$-1.25 \left(1 + \frac{R2}{R1} \right)$ See Figure 8

9.2.1.3 Application Performance

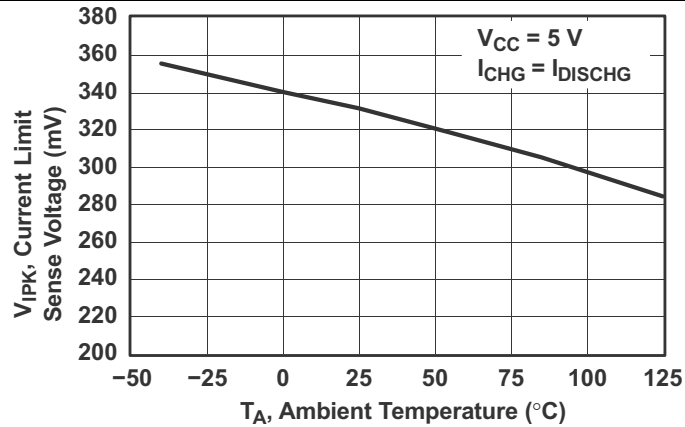

Figure 9. Current-Limit Sense Voltage vs Temperature

TEST	CONDITIONS	RESULTS
Line regulation	V _{IN} = 4.5 V to 6 V, I _O = 100 mA	3 mV ± 0.12%
Load regulation	V _{IN} = 5 V, I _O = 10 mA to 100 mA	0.022 V ± 0.09%
Output ripple	V _{IN} = 5 V, I _O = 100 mA	500 mV _{PP}
Short-circuit current	V _{IN} = 5 V, R _L = 0.1 Ω	910 mA
Efficiency	V _{IN} = 5 V, I _O = 100 mA	62.2%
Output ripple with optional filter	V _{IN} = 5 V, I _O = 100 mA	70 mV _{PP}

9.2.2 Step-Up Converter Application

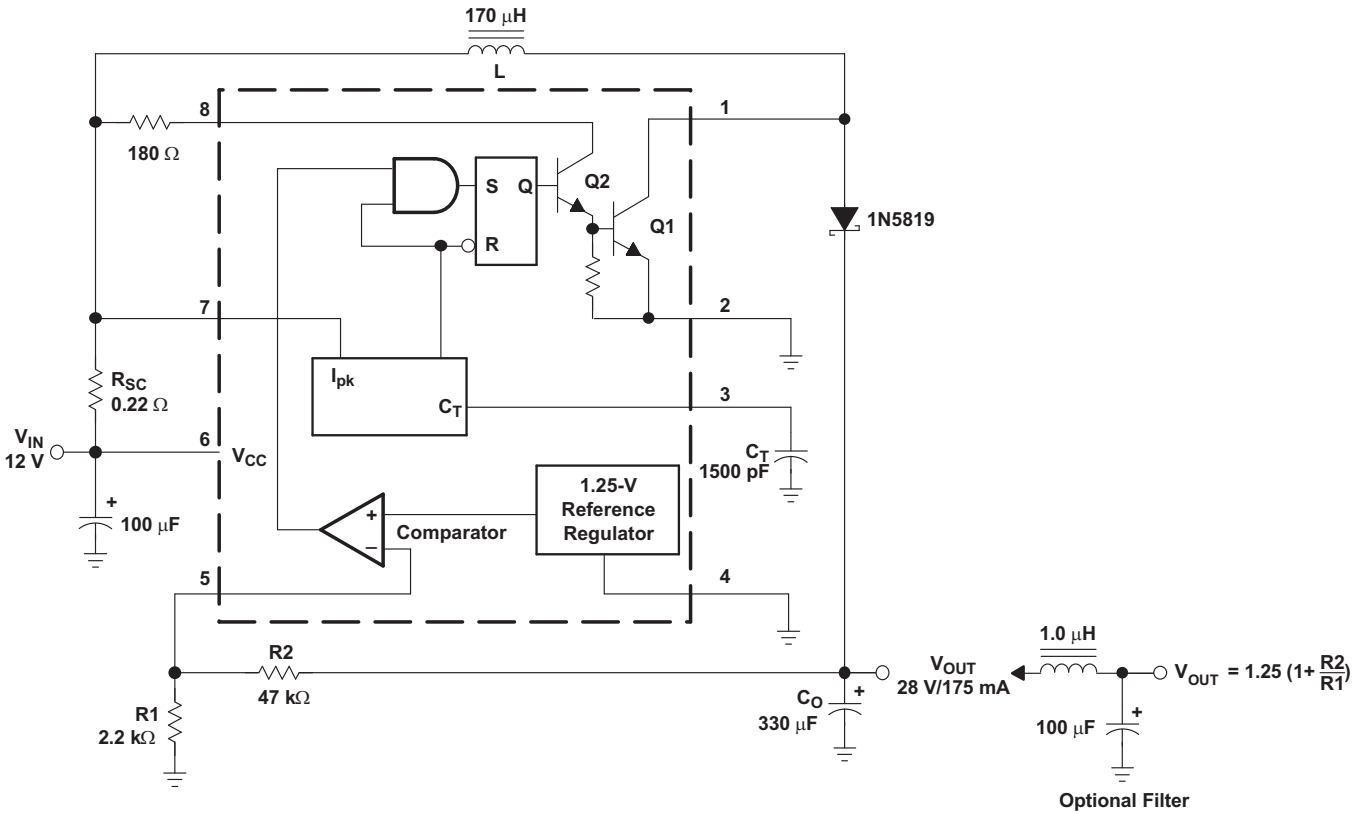

Figure 10. Step-Up Converter

9.2.2.1 Design Requirements

The user must determine the following desired parameters:

V_{sat} = Saturation voltage of the output switch

V_F = Forward voltage drop of the chosen output rectifier

The following power-supply parameters are set by the user:

V_{in} = Nominal input voltage

V_{out} = Desired output voltage

I_{out} = Desired output current

f_{min} = Minimum desired output switching frequency at the selected values of V_{in} and I_{out}

V_{ripple} = Desired peak-to-peak output ripple voltage. The ripple voltage directly affects the line and load regulation and, thus, must be considered. In practice, the actual capacitor value should be larger than the calculated value, to account for the capacitor's equivalent series resistance and board layout.

XD34063 DIP8/XD33063 DIP8–XL34063 SOP8/XL33063 SOP8

9.2.2.2 Detailed Design Procedure

CALCULATION	STEP UP
t_{on}/t_{off}	$\frac{V_{out} + V_{F-Vin(min)}}{V_{in(min)} - V_{sat}}$
$(t_{on} + t_{off})$	$\frac{1}{f}$
t_{off}	$\frac{t_{on} + t_{off}}{\frac{t_{on}}{t_{off}} + 1}$
t_{on}	$(t_{on} + t_{off}) - t_{off}$
C_T	$4 \times 10^{-5} t_{on}$
$I_{pk(switch)}$	$2I_{out(max)} \left(\frac{t_{on}}{t_{off}} + 1 \right)$
R_{SC}	$\frac{0.3}{I_{pk(switch)}}$
$L_{(min)}$	$\left(\frac{(V_{in(min)} - V_{sat})}{I_{pk(switch)}} \right) t_{on(max)}$
C_O	$9 \frac{I_{out} t_{on}}{V_{ripple(pp)}}$
V_{out}	$1.25 \left(1 + \frac{R2}{R1} \right)$ See Figure 10

9.2.2.3 Application Performance

TEST	CONDITIONS	RESULTS
Line regulation	$V_{IN} = 8 \text{ V to } 16 \text{ V}, I_O = 175 \text{ mA}$	$30 \text{ mV} \pm 0.05\%$
Load regulation	$V_{IN} = 12 \text{ V}, I_O = 75 \text{ mA to } 175 \text{ mA}$	$10 \text{ mV} \pm 0.017\%$
Output ripple	$V_{IN} = 12 \text{ V}, I_O = 175 \text{ mA}$	400 mV_{PP}
Efficiency	$V_{IN} = 12 \text{ V}, I_O = 175 \text{ mA}$	87.7%
Output ripple with optional filter	$V_{IN} = 12 \text{ V}, I_O = 175 \text{ mA}$	40 mV_{PP}

9.2.3 Step-Down Converter Application

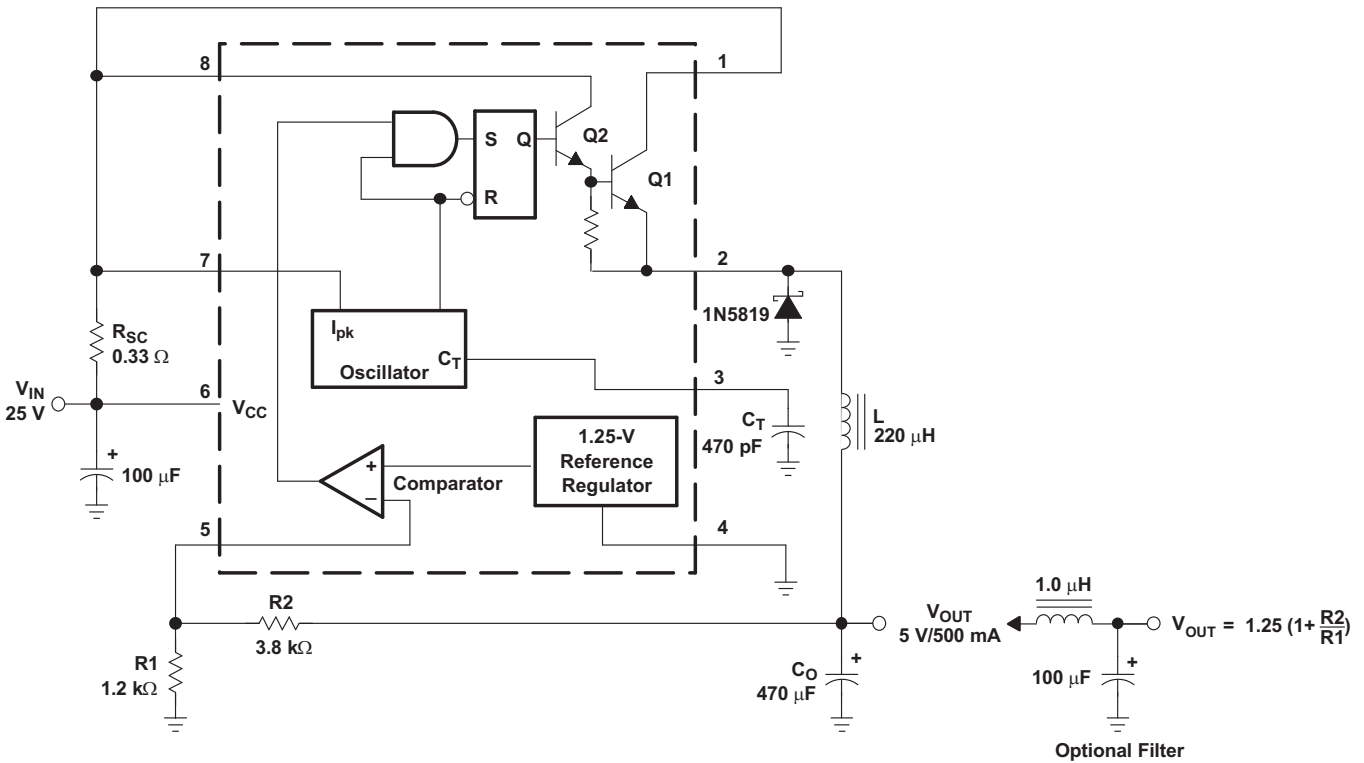

Figure 11. Step-Down Converter

9.2.3.1 Design Requirements

The user must determine the following desired parameters:

V_{sat} = Saturation voltage of the output switch

V_F = Forward voltage drop of the chosen output rectifier

The following power-supply parameters are set by the user:

V_{in} = Nominal input voltage

V_{out} = Desired output voltage

I_{out} = Desired output current

f_{min} = Minimum desired output switching frequency at the selected values of V_{in} and I_{out}

V_{ripple} = Desired peak-to-peak output ripple voltage. The ripple voltage directly affects the line and load regulation and, thus, must be considered. In practice, the actual capacitor value should be larger than the calculated value, to account for the capacitor's equivalent series resistance and board layout.

XD34063 DIP8/XD33063 DIP8–XL34063 SOP8/XL33063 SOP8

9.2.3.2 Detailed Design Procedure

CALCULATION	STEP DOWN
t_{on}/t_{off}	$\frac{V_{out} + V_F}{V_{in(min)} - V_{sat} - V_{out}}$
$(t_{on} + t_{off})$	$\frac{1}{f}$
t_{off}	$\frac{t_{on} + t_{off}}{\frac{t_{on}}{t_{off}} + 1}$
t_{on}	$(t_{on} + t_{off}) - t_{off}$
C_T	$4 \times 10^{-5} t_{on}$
$I_{pk(switch)}$	$2I_{out(max)}$
R_{SC}	$\frac{0.3}{I_{pk(switch)}}$
$L_{(min)}$	$\left(\frac{(V_{in(min)} - V_{sat} - V_{out})}{I_{pk(switch)}} \right) t_{on(max)}$
C_O	$\frac{I_{pk(switch)} (t_{on} + t_{off})}{8V_{ripple(pp)}}$
V_{out}	$1.25 \left(1 + \frac{R_2}{R_1} \right)$ See Figure 11

9.2.3.3 Application Performance

TEST	CONDITIONS	RESULTS
Line regulation	$V_{IN} = 15 \text{ V to } 25 \text{ V}, I_O = 500 \text{ mA}$	$12 \text{ mV} \pm 0.12\%$
Load regulation	$V_{IN} = 25 \text{ V}, I_O = 50 \text{ mA to } 500 \text{ mA}$	$3 \text{ mV} \pm 0.03\%$
Output ripple	$V_{IN} = 25 \text{ V}, I_O = 500 \text{ mA}$	120 mV_{PP}
Short-circuit current	$V_{IN} = 25 \text{ V}, R_L = 0.1 \Omega$	1.1 A
Efficiency	$V_{IN} = 25 \text{ V}, I_O = 500 \text{ mA}$	83.7%
Output ripple with optional filter	$V_{IN} = 25 \text{ V}, I_O = 500 \text{ mA}$	40 mV_{PP}

10 Power Supply Recommendations

This device accepts 3 V to 40 V on the input. It is recommended to have a 1000- μF decoupling capacitor on the input.

11 Layout

11.1 Layout Guidelines

Keep feedback loop layout trace lengths to a minimum to avoid unnecessary IR drop. In addition, the loop for the decoupling capacitor at the input should be as small as possible. The trace from V_{IN} to pin 1 of the device should be thicker to handle the higher current.

11.2 Layout Example

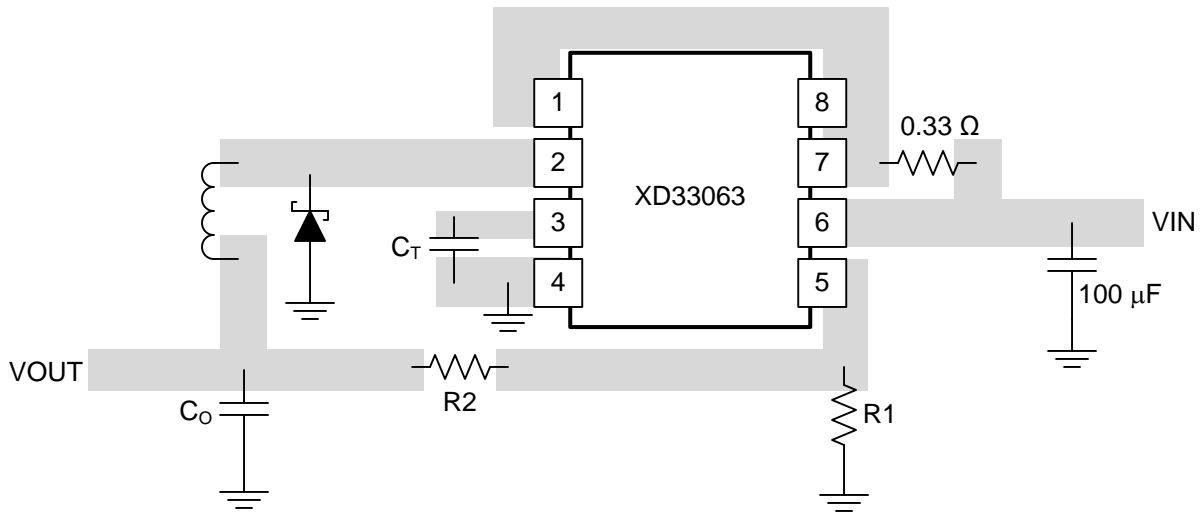
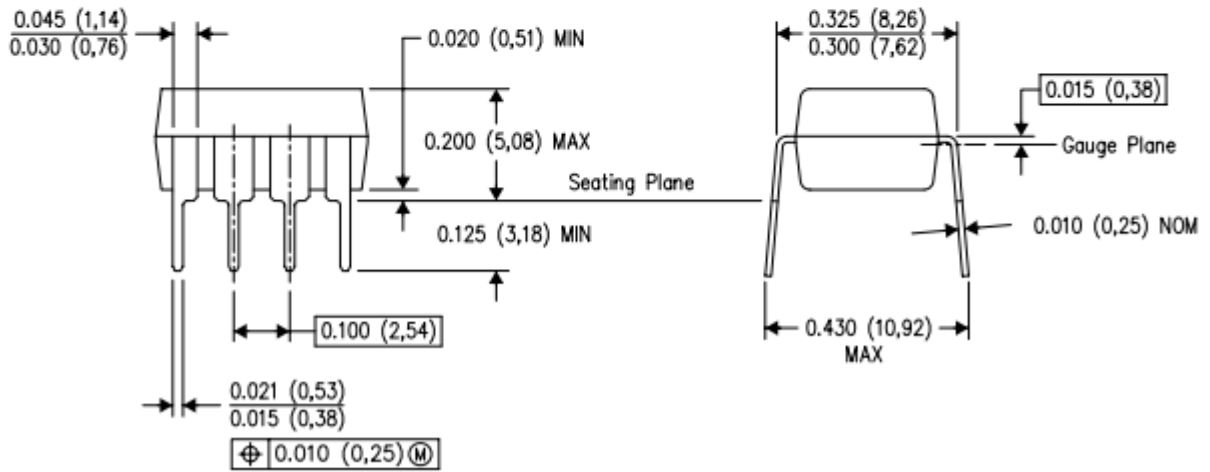
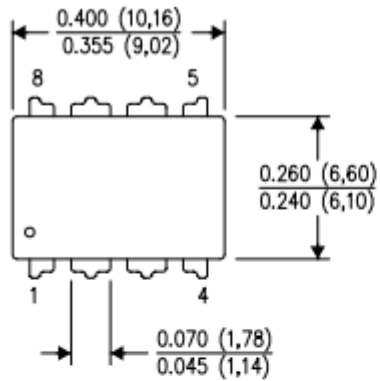

Figure 12. Layout Example for a Step-Down Converter

XD34063 DIP8/XD33063 DIP8-XL34063 SOP8/XL33063 SOP8

DIP



XD34063 DIP8/XD33063 DIP8-XL34063 SOP8/XL33063 SOP8

SOP

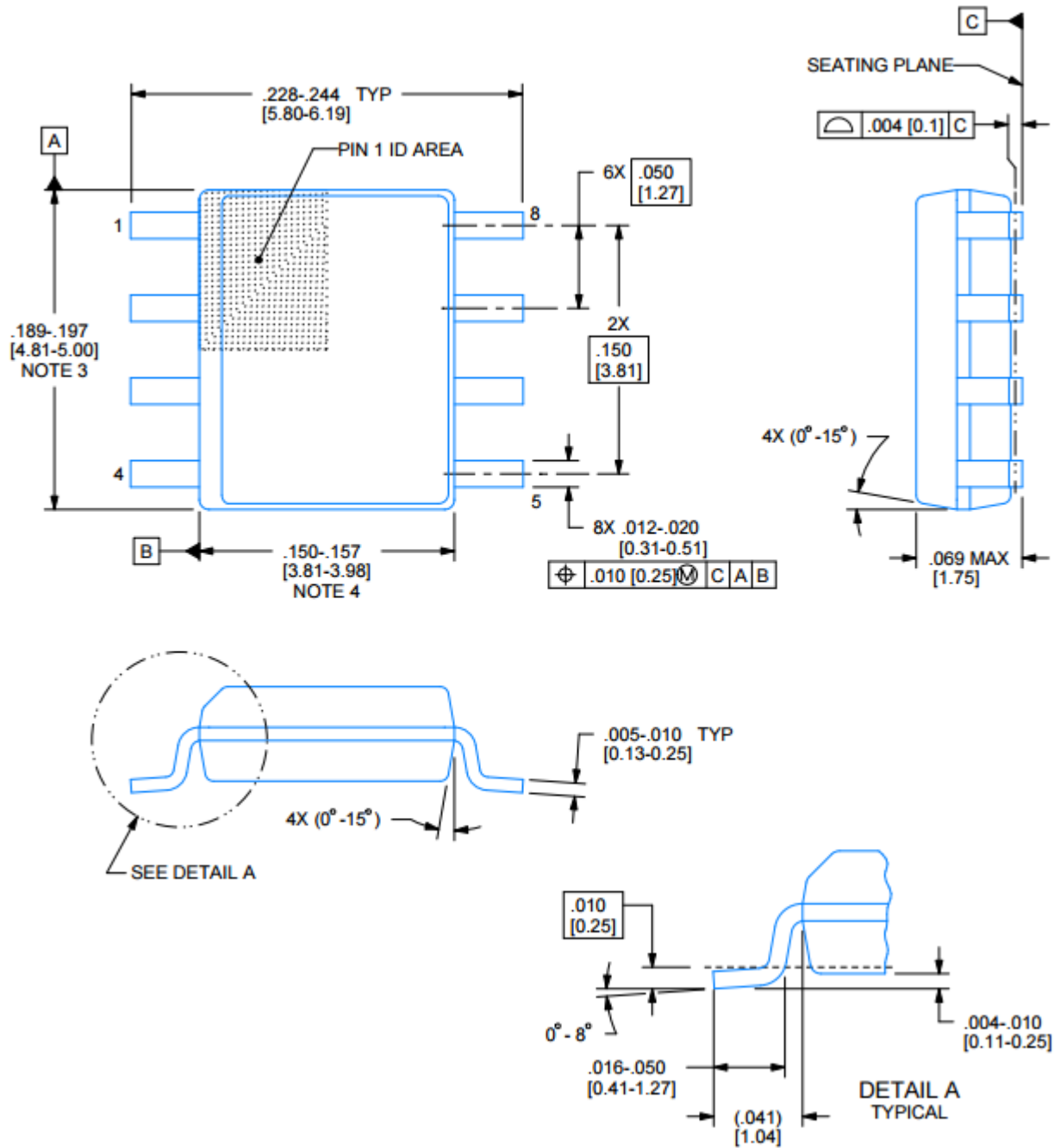

以上信息仅供参考. 如需帮助联系客服人员。谢谢 XINLUDA