

SPECIFICATIONS

产品规格书

客户名称 Customer		产品名称 Product	TX1812HA
客户代码 Customer NO.		产品型号 Type	TC3838RGB-3CSA- TX1812HA

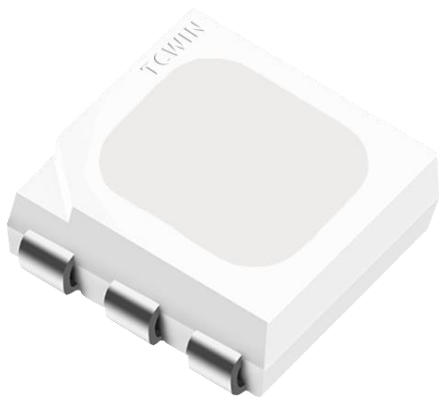

3838 内置 IC 幻彩

智能外控 LED 光源

3.5 x 3.5 x 1.3 mm

0.2W SMD LED 器件



地址：深圳市宝安区松岗街道东方大道 33 号

电话：0755-29573599 29573979 传真：0755-29573533

网址：<http://www.tczmled.com> 邮编：518106



目 录

1、产品概述.....	3
2、主要应用.....	3
3、特征说明.....	3
4、产品尺寸.....	4
5、产品命名规则.....	4
6、引脚功能.....	5
7、RGB 光电特性.....	5
8、绝对最大值.....	6
9、IC 电气参数.....	6
10、开关特性.....	6
11、数据传输时间.....	7
12、时序波形图.....	7
13、数据传输方式.....	8
14、24bit 数据结构.....	8
15、典型应用电路.....	8
16、光电特性曲线.....	9
17、包装.....	10
18、可靠性测试.....	11
19、焊接说明.....	112
20、注意事项.....	113

1. Description(产品描述)

TX1812HA 是一个集控制电路与发光电路于一体的智能外控 LED 光源。其外型与一个 3838LED 灯珠相同, 每个元件即为一个像素点。像素点内部包含了智能数字接口数据锁存信号整形放大驱动电路, 电源稳压电路, 内置恒流电路, 高精度 RC 振荡器, 输出驱动采用专利 PWM 技术, 有效保证了像素点发光颜色一致性。

数据协议采用单极性归零码的通讯方式, 像素点在上电复位以后, DIN 端接受从控制器传输过来的数据, 首先送过来的 24bit 数据被第一个像素点提取后, 送到像素点内部的数据锁存器, 剩余的数据经过内部整形处理电路整形放大后通过 DO 端口开始转发输出给下一个级联的像素点, 每经过一个像素点的传输, 信号减少 24bit。

LED 具有低电压驱动, 环保节能, 亮度高, 散射角度大, 一致性好, 超低功率, 超长寿命等优点。将控制电路集成于 LED 上面, 电路变得更加简单, 体积小, 安装更加简便。

2. Applications (主要应用)

- LED 全彩发光字灯串, LED 全彩模组, LED 幻彩软硬灯条, LED 护栏管, LED 外观/情景照明。
- LED 点光源, LED 像素屏, LED 异形屏, 机箱风扇氛围灯, 各种电子产品, 电器设备跑马灯。

3. Features (特征说明)

- LED 内部集成高质量外控单线串行级联恒流 IC;
- 控制电路与芯片集成在 SMD 3838 元器件中, 构成一个完整的外控像素点, 效果均匀且一致性高;
- 内置数据整形电路, 任何像素点收到信号后经过波形整形再输出, 保证线路波形畸变不会累加;
- 内置上电复位和掉电复位电路, 默认上电不亮灯;
- 灰度调节电路 (256 级灰度可调);
- 红光驱动特殊处理, 配色更均衡;
- 单线数据传输, 可无限级联;
- 整形转发强化技术, 两点间传输距离超过 10M;
- 数据传输频率可达 800Kbps, 当刷新速率 30 帧/秒时, 级联数不小于 1024 点。

4. Package Dimensions (产品尺寸)

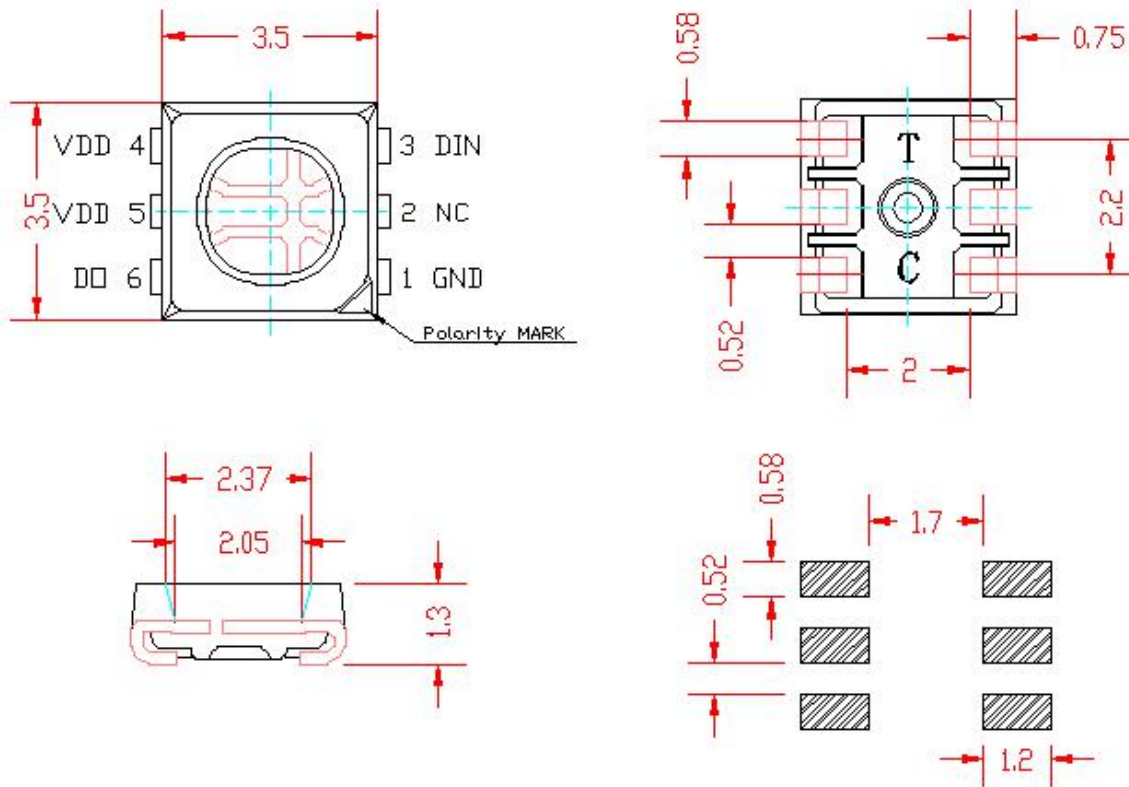

Recommended size of solder pad

建议焊盘尺寸

注:

- 所有标注尺寸的单位均为 mm;
- 除了特别注明, 所有标注尺寸的公差均为 $\pm 0.2\text{mm}$;
- 封装尺寸: $3.5 \times 3.5 \times 1.3\text{mm}$;

5. Product naming principle (产品命名规则)

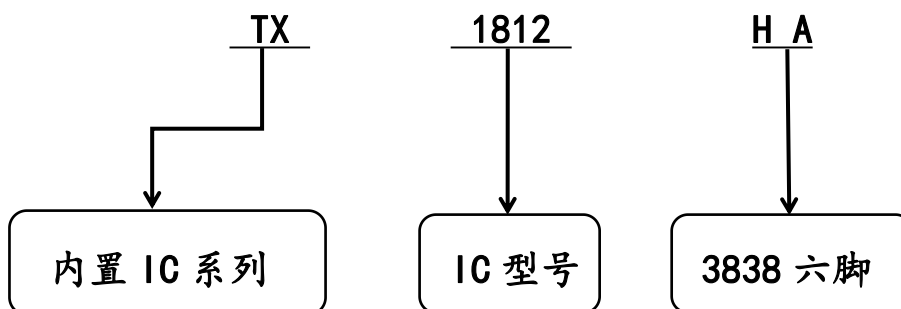

6. Pin function (引脚功能)

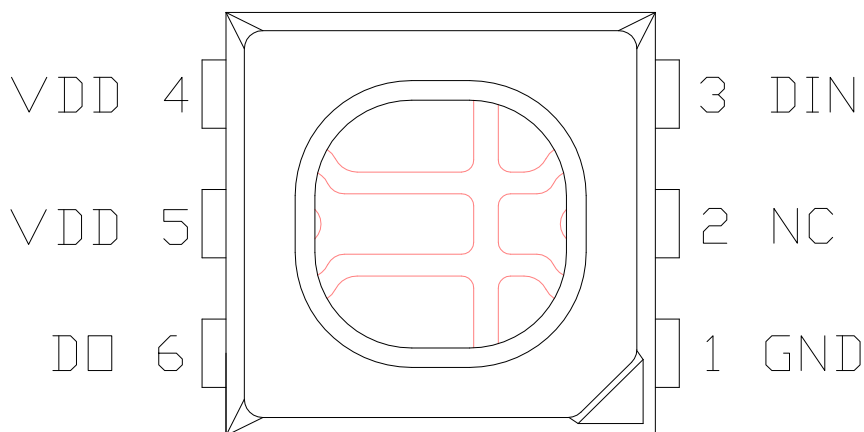

序号	符号	管脚名	功能描述
1	GND	地	信号接地和电源接地
2	NC	空脚	PCB上做悬空处理
3	DIN	数据输入	控制数据信号输入
4	VDD	电源	供电管脚, PCB上两供电管脚可做连通处理
5	VDD	电源	供电管脚, PCB上两供电管脚可做连通处理
6	DO	数据输出	控制数据信号输出

7. Electro-optical characteristics at Ta=25°C (RGB 光电特性)

Item 项目	Symbol (符号)	Mix (最小)	Typ (平均)	Max (最大)	Unit (单位)	Conditions (测试条件)	
Dominant wavelength (主波长)	λ_d	G	520		525	nm	IF=12mA
		R	620		625		
		B	465		470		
Luminous intensity (发光强度)	IV	G	800		1200	mcd	IF=12mA
		R	200		400		
		B	150		300		

8. Absolute maximum ratings at Ta=25°C (绝对最大额定值)

参数	符号	范围	单位
逻辑电源电压	V _{DD}	3.5~7.5	V
逻辑输入电压	V _I	-0.5~5.5	V
工作温度	T _{opt}	-40~85	°C
储存温度	T _{stg}	-40~120	°C
ESD耐压	V _{ESD}	4K	V

9. IC Electric Spec (IC 电气参数)

参数	符号	最小	典型	最大	单位	测试条件
R/G/B输出端口耐压	V _{ds}	8.5	9	9.5	V	--
R/G/B输出驱动电流	I _o	9.6	12	14.4	mA	--
高电平输入电压	V _{IH}	0.7V _{DD}	0.9V _{DD}	V _{DD}	V	--
低电平输入电压	V _{IL}	0	0.1V _{DD}	0.3V _{DD}	V	--
DO拉电流能力	I _{DOH}	--	15	--	mA	--
DO拉电流能力	I _{DOL}	--	30	--	mA	--
PWM频率	F _{PWM}	3	4	5	KHZ	--
静态功耗	I _{DD}	0.6	0.8	1	mA	--

10. Dynamic parameter (开关特性)

参数	符号	最小	典型	最大	单位	测试条件
数据传输速率	F _{DIN}	--	800	1100	KHZ	--
传输延迟时间	T _{PLZ}	--	--	200	ns	DIN→DO
输出电流转换时间	T _r	--	--	400	ns	V _{ds} =1.5V I _o =12mA
	T _f	--	--	400	ns	

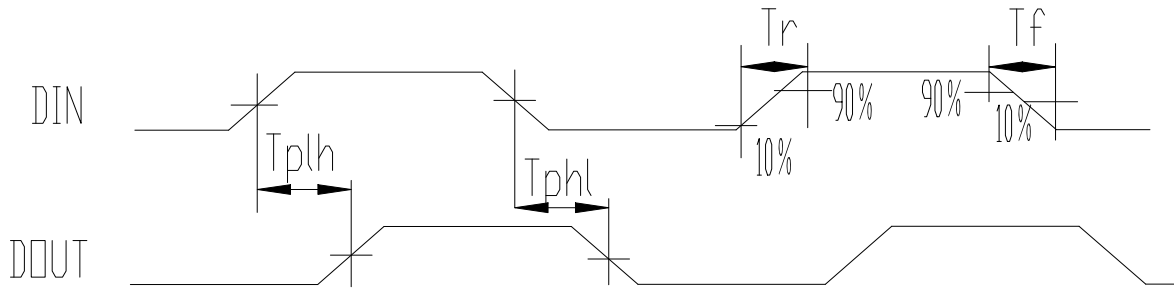

11. The data transmission time (数据传输时间)

T符号	码元Code	Min	Typical	Max	Unit
TOH	0码, 高电平时间	245	295	345	ns
TOL	0码, 低电平时间	545	595	645	ns
TIH	1码, 高电平时间	545	595	645	ns
TIL	1码, 低电平时间	245	295	345	ns
Trst	Reset码, 低电平时间	80	--	--	us

12. Temporal waveform figure (时序波形图)

输入码型:

连接方式:

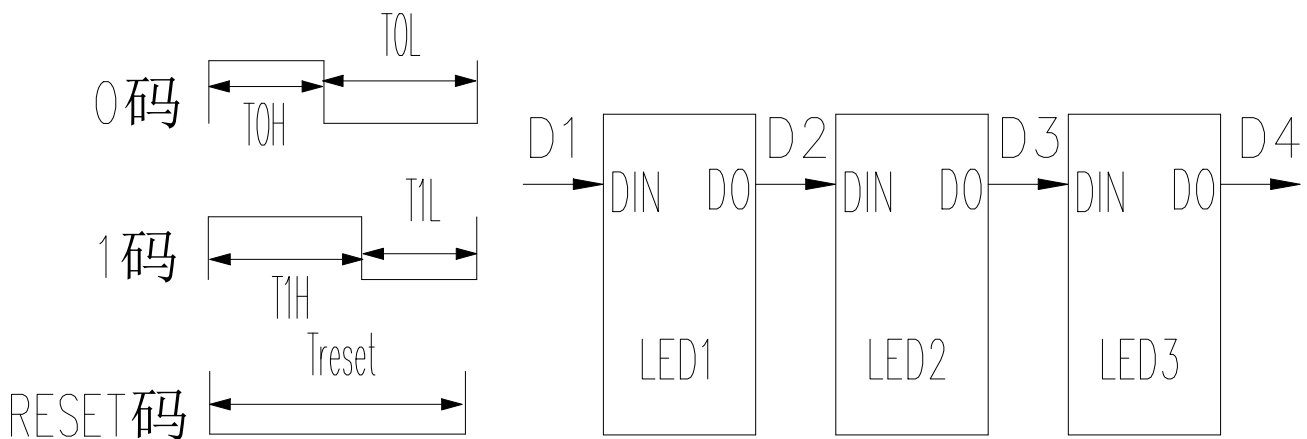

13. Mode of data transmission (数据传输方式)

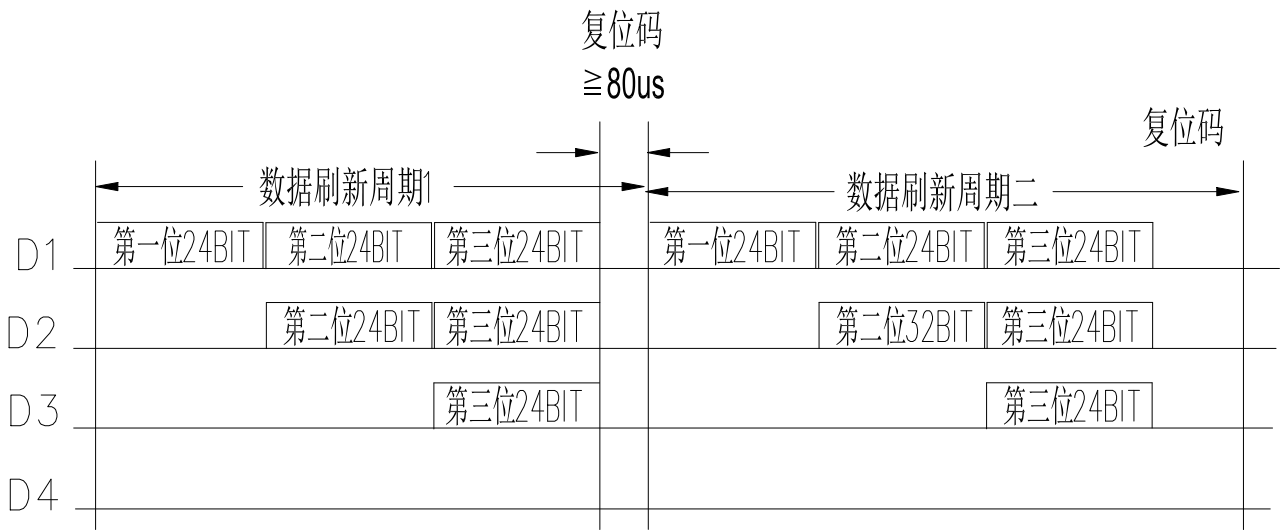

注：其中 D1 为 MCU 端发送的数据，D2、D3、D4 为级联电路自动整形转发的数据

14. Mode of data transmission (24bit 数据结构)

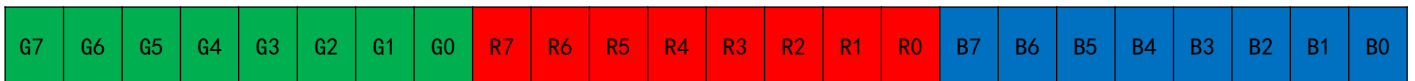

注：高位先发，按照 GRB 的顺序发送数据 (G7→G6……B0)

15. Typical application circuit (典型应用电路)

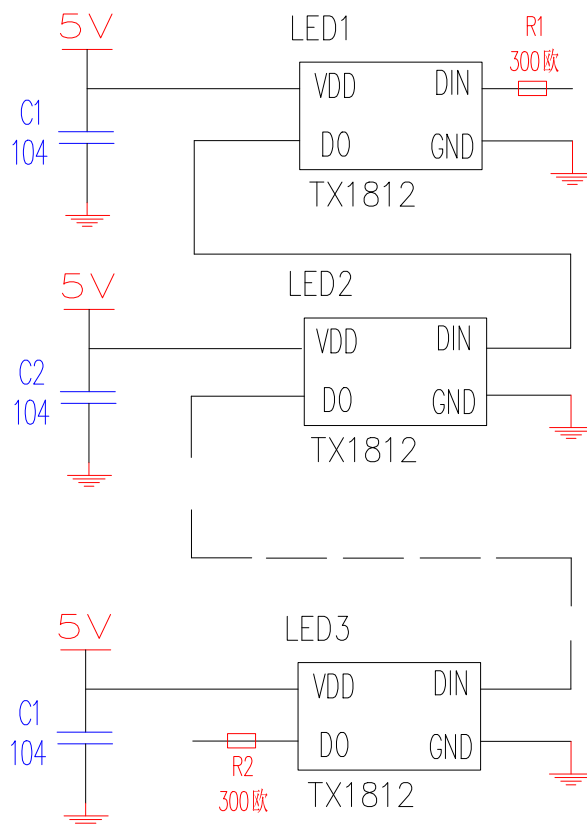

16. Typical optical characteristics curves (光电特性曲线)

Spectral Distribution

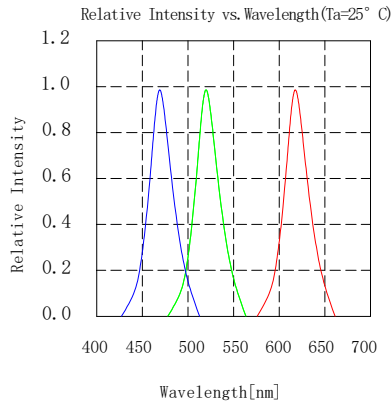

Forward current vs. Forward Voltage (Ta=25° C)

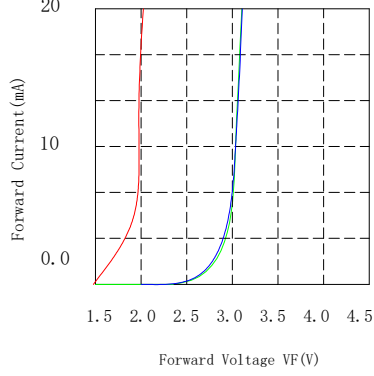

Relative Intensity vs. Forward Current (Ta=25° C)

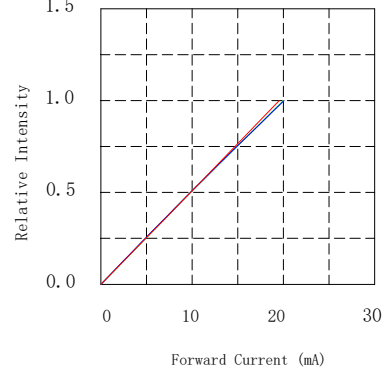

Detrating

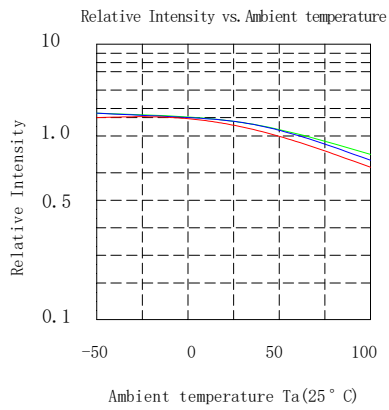

Ambient temperature vs. Maximum Forward Current

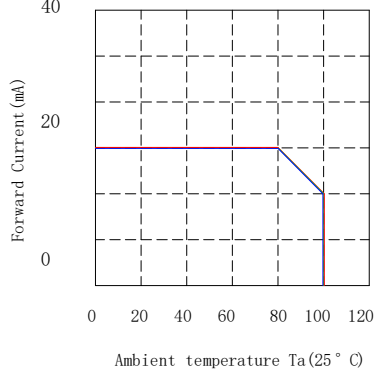

Forward Current vs. Chromating (Ta=25° C)

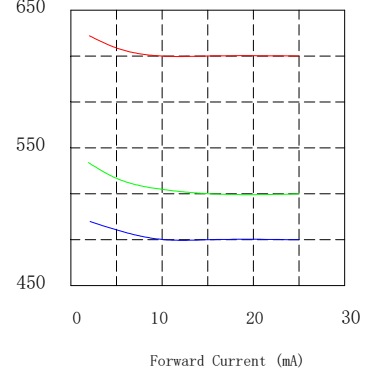
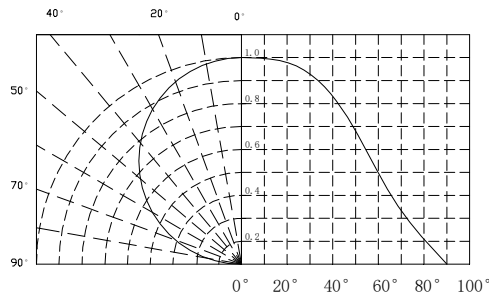
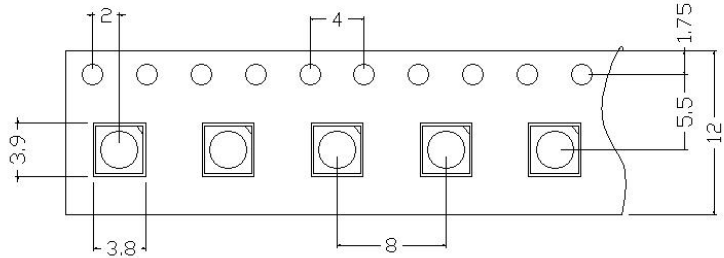

Diagram characteristics of radiation



17. Packaging Specifications (包装规格)

● Feeding Direction (进料方向)



卷盘尺寸: 178x12mm

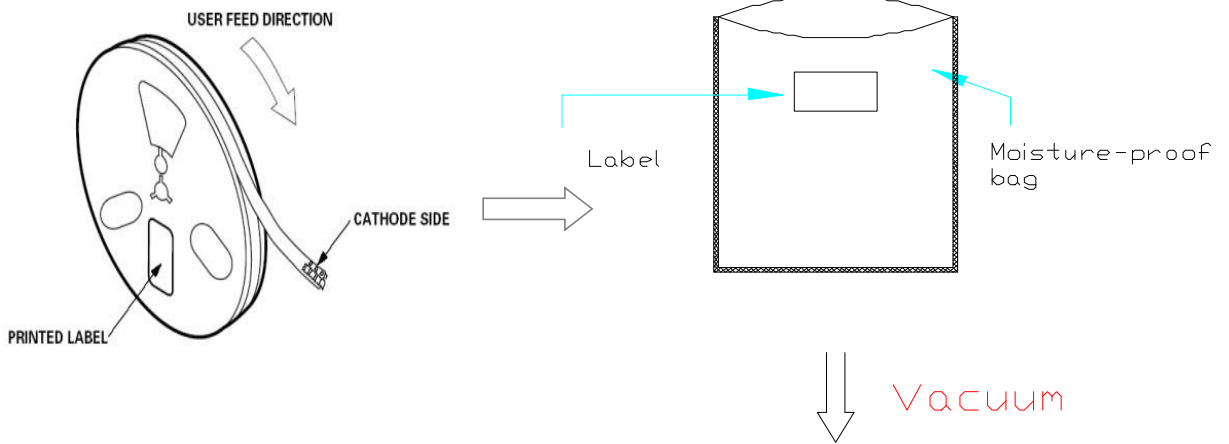

深圳市天成照明有限公司
 PN:TC3838RGB-3CJH
 SN:TX1812EB-12345678
 CIEXY:IC 3838四脚 幻彩灯珠 2020.12.11
 QTY:1003pcs

IF12mA	R	G	B
VF(v)	2.0-2.2	3.0-3.2	3.0-3.2
IV(mcd)	500-700	1300-1800	300-500
λd(nm)	620-625	525-530	465-470

真空包装拆包后必须在8小时内使用完成

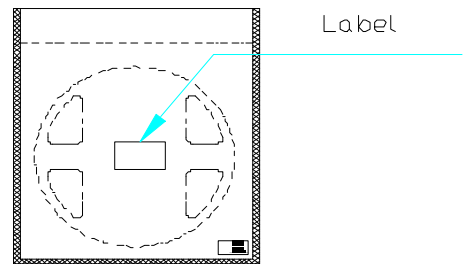
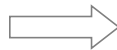

标签图示

Note: volume is 1000pcs; 每卷数量 1000pcs;

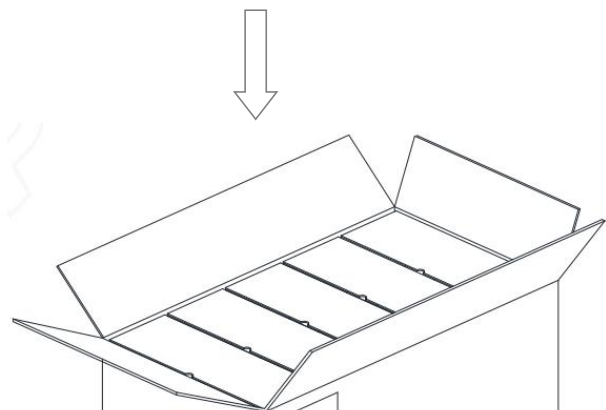

18. Reliability (可靠性)

TEST ITEMS AND RESULTS (测试项目和结果)

序号	Test Item (测试项目)	Ref. Standard (参考标准)	Test Conditions (测试条件)	Note (备注)	Conclusion (结论)
1	Reflow Soldering (回流焊)	JESD22-B106	T _{sld} =240°C, 10sec	3 times	0/22
2	Temperature Cycle (温度循环)	JESD22-A104	-20°C 30min ↑ ↓ 15min 120°C 30min	200 cycle	0/22
3	Thermal Shock (冷热冲击)	JESD22-A106	-40°C 15min ↑ ↓ 15sec 125°C 15min	200 cycle	0/22
4	High Temperature Storage (高温存储)	JESD22-A103	T _a =100°C	1000 hrs	0/22
5	Low Temperature Storage (低温存储)	JESD22-A119	T _a =-40°C	1000 hrs	0/22
6	Power temperature Cycling (点亮高低温循环)	JESD22-A105	On 5min -40°C > 15min ↑ ↓ ↑ ↓ < 15min Off 5min 100°C > 15min	200 cycle	0/22
7	Life Test (老化测试)	JESD22-A108	T _a =25°C I _F =12mA	1000 hrs	0/22
8	High Humidity Heat Life Test (高温高湿)	JESD22-A101	60°C RH=90% I _F =12mA	1000 hrs	0/22

19. Reflow profile (焊接说明)

■ SMD Reflow Soldering Instructions (回流焊简介)

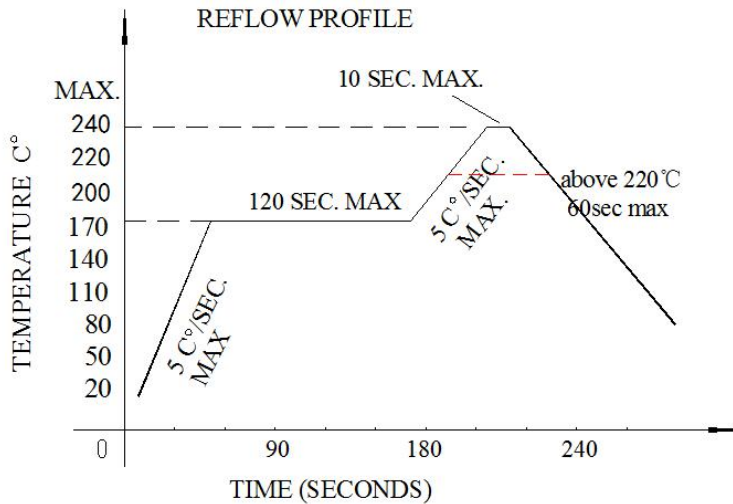

- a. Reflow soldering should not be done more than two times

回流焊次数不应超过 2 次

- b. When soldering ,do not put stress on the LEDs during heating

焊接时，在加热过程中不能有应力作用于 LED 灯珠

■ Soldering iron (烙铁)

- a. When hand soldering, keep the temperature of the iron under 300°C, and at that temperature keep the time under 3 sec.

手工焊接时，烙铁温度控制在 300°C 以下，且时间不可超过 3 秒

- b. The hand soldering should be done only a time 手工焊接只可焊接一次；

■ Rework (返工)

- a. Customer must finish rework within 5 sec under 240°C

温度保持在 240°C 以下，5 秒内完成返工作业

- b. The head of iron can not touch the LEDs

烙铁不能碰触到 LED 灯珠

- c. Twin-head type is preferred. 双头形烙铁为最佳

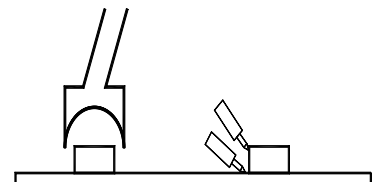

20. CAUTIONS (注意事项)

➤ Note for use 使用注意事项

In order to ensure that IC lamp beads are used in SMT patch reflow welding and in the use of the process yield and stability of the product, the following procedures are specified after many tests:

为确保内置 IC 灯珠产品在 SMT 贴片回流焊和使用过程良率及产品稳定性，经过多次试验验证特制订以下各工序相关注意事项如下：

a、 Sample evaluation: Because this product is a built-in IC product, the overall process is different from conventional RGB products, so the customer side needs to carry out all-round verification during the sample evaluation to ensure the matching performance of the product;

样品评估：因本产品为内置 IC 产品，整体工艺差别于常规 RGB 产品，所以客户端在样品评估时需进行全方位验证，确保产品的匹配性能；

b、 Incoming material inspection: ensure the vacuum packing is intact and there is no vacuum leakage. If there is vacuum leakage, please confirm whether the reflow welding is abnormal. If it is abnormal, please return to the factory for high-temperature dehumidification.

来料检验：确保真空包装完好，无漏真空现象，如有漏真空请确认回流焊是否异常，如异常需返厂重新高温除湿；

c、 Use: Please confirm the first piece before the formal SMT. According to the principle of one pack and one package, the lamp bead should not be exposed to air for more than 4 hours. The lamp bead should be reflow welded within 2 hours after the SMT is finished.

使用：正式贴片前请先做好首件确认，使用时按拆一包用一包的原则，灯珠裸露在空气中不得超过 4 小时，贴片完成灯珠需在 2 小时以内过完回流焊，使用锡膏为中低温锡膏，回流焊最高

温度不得超过 240 度；

d、Maintenance: material should be completed within 4 hours and domestic demand after reflow soldering test and repair the lamp bead, such as more than 4 hours need to repair the lamp plate temperature above 65 °C dehumidification 12 hours to repair work, and repair the lamp bead also must carry on the low temperature above 65 °C dehumidification 12 hours, use prohibited in the process of maintenance with temperature over 240 °C heating machine repair, prohibit the whole plate placed in the heating stage repair, follow the principle of bad which return which measuring.

维修：材料在回流焊后 4 小时内需完成测试和维修灯珠，如超过 4 小时需将要维修灯板低温 65°C 除湿 12 小时以上才可进行维修作业，且维修所需的灯珠也要进行低温 65°C 除湿 12 小时以上才可使用，维修过程中禁止用温度超过 240°C 加热台进行返修，禁止整板放置于加热台上返修，遵循坏哪颗返哪颗的原则。

e、Warm prompt: the whole process special considerations for light bead before use vacuum packing, dehumidification, SMT placement time and workshop of temperature and humidity control, product maintenance lamp plate if bare at room temperature environment for a long time need to dehumidification, light board and light bead light beads as LED electronic products, need to pay attention to moisture in spring and summer, autumn and winter anti-static, product quality is enterprise's life, to the quality strives for the survival, to the quality strives for the development is our consistent aim. Also in order to ensure the quality of the client, please strictly refer to the above recommendations

温馨提示：整个工序特别注意事项为灯珠使用前真空包装、除湿后贴片放置时间和车间的湿度管控，产品维修时灯板如裸露在室温环境时间过长灯板和灯珠需进行除湿，灯珠为 LED 电子元器件产品，需注意春夏季防潮，秋冬季防静电，产品品质就是一家企业的生命，以质量求生存，以质量求发展是我司的一贯宗旨。也为保证客户端品质，请严格参照以上建议操作。

防潮等级定义

防潮等级验证						
防潮等级	材料拆包后使用寿命		验证条件			
	时间	条件	标准条件		加速条件	
			时间	条件	时间	条件
LEVEL1	无限制	≅ 30°C/85%RH	168+5/-0H	85°C/85%RH	/	/
LEVEL2	1 年	≅ 30°C/60%RH	168+5/-0H	85°C/60%RH	/	/
LEVEL2a	4 周	≅ 30°C/60%RH	696+5/-0H	30°C/60%RH	120+5/-0H	60°C/60%RH
LEVEL3	168 小时	≅ 30°C/60%RH	192+5/-0H	30°C/60%RH	40+5/-0H	60°C/60%RH
LEVEL4	72 小时	≅ 30°C/60%RH	96+5/-0H	30°C/60%RH	20+5/-0H	60°C/60%RH
LEVEL5	48 小时	≅ 30°C/60%RH	72+5/-0H	30°C/60%RH	15+5/-0H	60°C/60%RH
LEVEL5a	24 小时	≅ 30°C/60%RH	48+5/-0H	30°C/60%RH	10+5/-0H	60°C/60%RH
LEVEL6	取出即用	≅ 30°C/60%RH	取出即用	30°C/60%RH	/	/

- The encapsulated material of the LEDs is silicone. Therefore the LEDs have a soft surface on the top of package. The pressure to the top surface will be influence to the reliability of the LEDs. Precautions should be taken to avoid the strong pressure on the encapsulated part. So when using the picking up nozzle, the pressure on the silicone resin should be proper.

封装的 LED 为硅材料。该 LED 具有软表面的封装顶部。顶部表面的压力会影响 LED 的可靠性。应采取预防措施，以避免有过大的压力作用于在封装件上。因此，在选用吸嘴时，应适用于有机硅树脂的压力。

