

# D款, 正向10.0前两脚, DIP-\*5.70

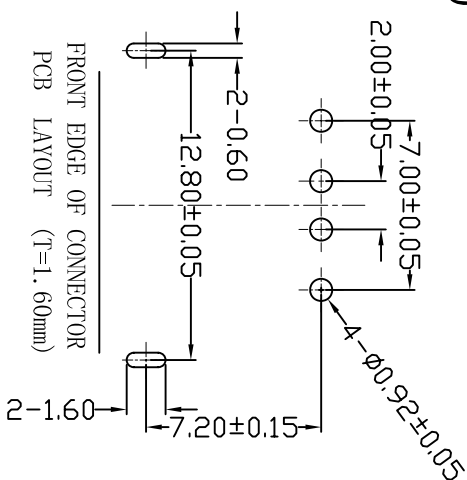

FRONT EDGE OF CONNECTOR  
PCB LAYOUT (T=1.60mm)

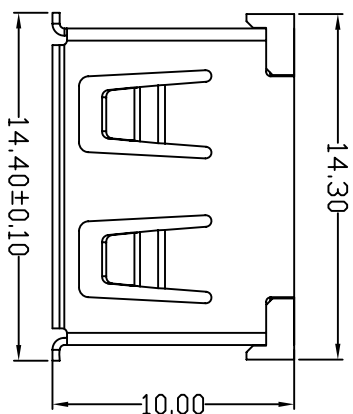
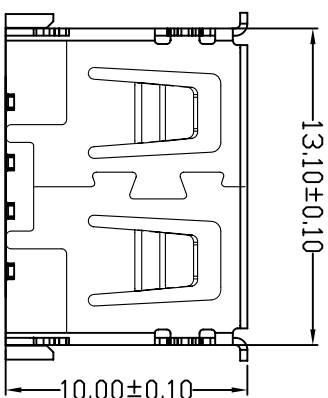
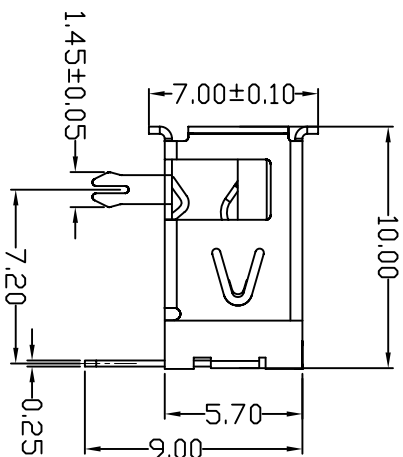
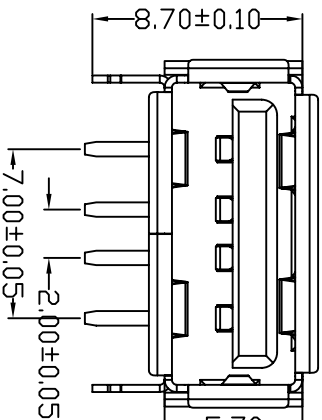

## NOTES:

1. HOUSING: SEE NOTES, UL94V-0.  
TERMINAL: SEE NOTES.  
SHELL: SEE NOTES.

## SPECIFICATION:

1. ELECTRICAL CHARACTERISTIC:  
CONTACT RESISTANCE: 30MΩ MAX  
DIELECTRIC WITHSTANDING VOLTAGE: 500V AC FOR 1MIN  
INSULATION RESISTANCE: 1000MΩ MIN

2. MECHANICAL CHARACTERISTIC:  
INSERTION FORCE: 35N(3.57KGF) MAX  
EXTRACTION FORCE: 10~35N(1.02~3.57KGF)/MIN  
DURABILITY: 1500 CYCLES EXTRACTION FORCE: 10~35N  
5000 CYCLES MIN

## 3. ENVIRONMENTAL:

OPERATING TEMPERATURE: -55°C+85°C

## 4. Contact finish:

01: Selective Gold Flash  
02: Selective Gold 3U"  
03: Selective Gold 5U"  
04: Selective Gold 15U"  
05: Selective Gold 30U"

## 产品图

# 深圳市精拓金电子有限公司

| 公差一览表                      |           | 单位    |          | 制图      |       | 制图料号             |                         |
|----------------------------|-----------|-------|----------|---------|-------|------------------|-------------------------|
| TOLERANCE UNLESS OTHERWISE | OTHERWISE | UNITS | MM       | DRAWING | Z-Y-B | PRODUCT PART NO. | JTY-USB-10.0-005        |
| X                          | ±5°       | SCALE | 1:1      | 审核      |       | 产品名称             | USB A/F 10.0前边前两脚鱼叉(方排) |
| X                          | ±2°       | 日期    | 20120924 | 核准      |       | PRODUCT NO.      |                         |
| XX                         | ±1°       | DATE  |          | APPD    |       | 角法               |                         |
| XXX                        | ±0.5°     |       |          |         |       | VER              | 版本                      |
|                            |           |       |          |         |       |                  | AD                      |

MAPX

MODIFICATION

DATE