

General Description

TD1465 is a 600mA synchronous buck converter with integrated 900mΩ power MOSFETs. The TD1465 design with a current-mode control scheme, can convert wide input voltage of 4.5V to 40V to the output voltage adjustable from 0.8V to 75%V_{IN} to provide excellent output voltage regulation. The TD1465 equipped with Power-on-reset, soft start and whole protections (under-voltage, over temperature and current-limit) into a single package.

This device, available SOT-23-6 provides a very compact system solution of external components and PCB area.

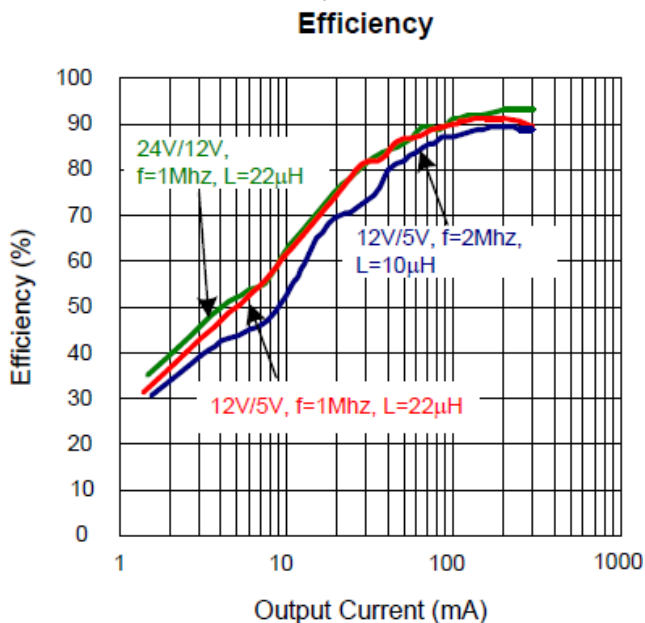

Features

- Wide Input Voltage from 4.5V to 40V
- 600mA Output Current
- High Efficiency over 85% from Load Current 30mA to 100mA @ V_{OUT} ≥ 5V
- Low EMI Converter
- Adjustable Output Voltage from 0.8V to 75%V_{IN}
- Integrated 900mΩ High/Low Side MOSFET
- 1M or 2Mhz Switching Frequency
- Stable with Low ESR Capacitors
- Power-On-Reset Detection
- Over-Temperature Protection
- Current-Limit Protection
- Enable/Shutdown Function
- Available in SOT-23-6 packages
- Lead Free and Green Devices Available (RoHS compliant)

Applications

- Smart Electronic equipments

Package Types



SOT23-6

Figure 1. Package Types of TD1465

Pin Configurations

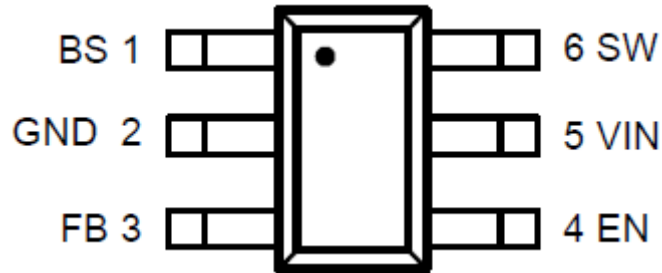
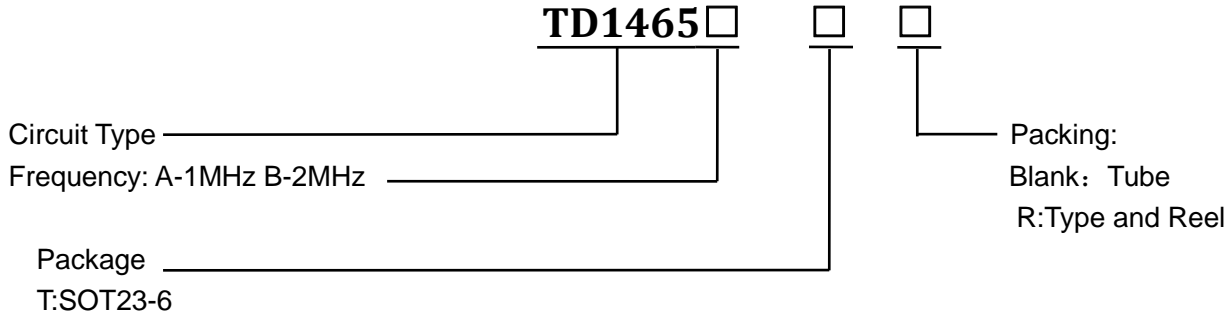

Figure 2 Pin Configuration of TD1465(Top View)

Pin Description

Pin Number	Pin Name	Description
1	BS	High-Side Gate Drive Boost Input. BS supplies the voltage to drive the high-side N-channel MOSFET. At least 10nF capacitor should be connected from SW to BS to supply the high side switch.
2	GND	Signal and power ground.
3	FB	Output feedback Input. The TD1465 senses the feedback voltage via FB and regulates the voltage at 0.8V. Connecting FB with a resistor-divider from the converter's output sets the output voltage from 1V to 80%V _{IN} .
4	EN	Enable Input. EN is a digital input that turns the regulator on or off. EN threshold is 1.4V with 0.2V hysteresis. Pull up with 100kΩ resistor for automatic startup.
5	VIN	Power Input. VIN supplies the power (4.5V to 40V) to the control circuitry, gate drivers and step-down converter switches. Connecting a ceramic bypass capacitor and a suitably large capacitor between VIN and GND eliminates switching noise and voltage ripple on the input to the IC.
6	SW	Power Switching Output. It is the Drain of the N-Channel power MOSFET to supply power to the output LC filter.

Ordering Information



Function Block

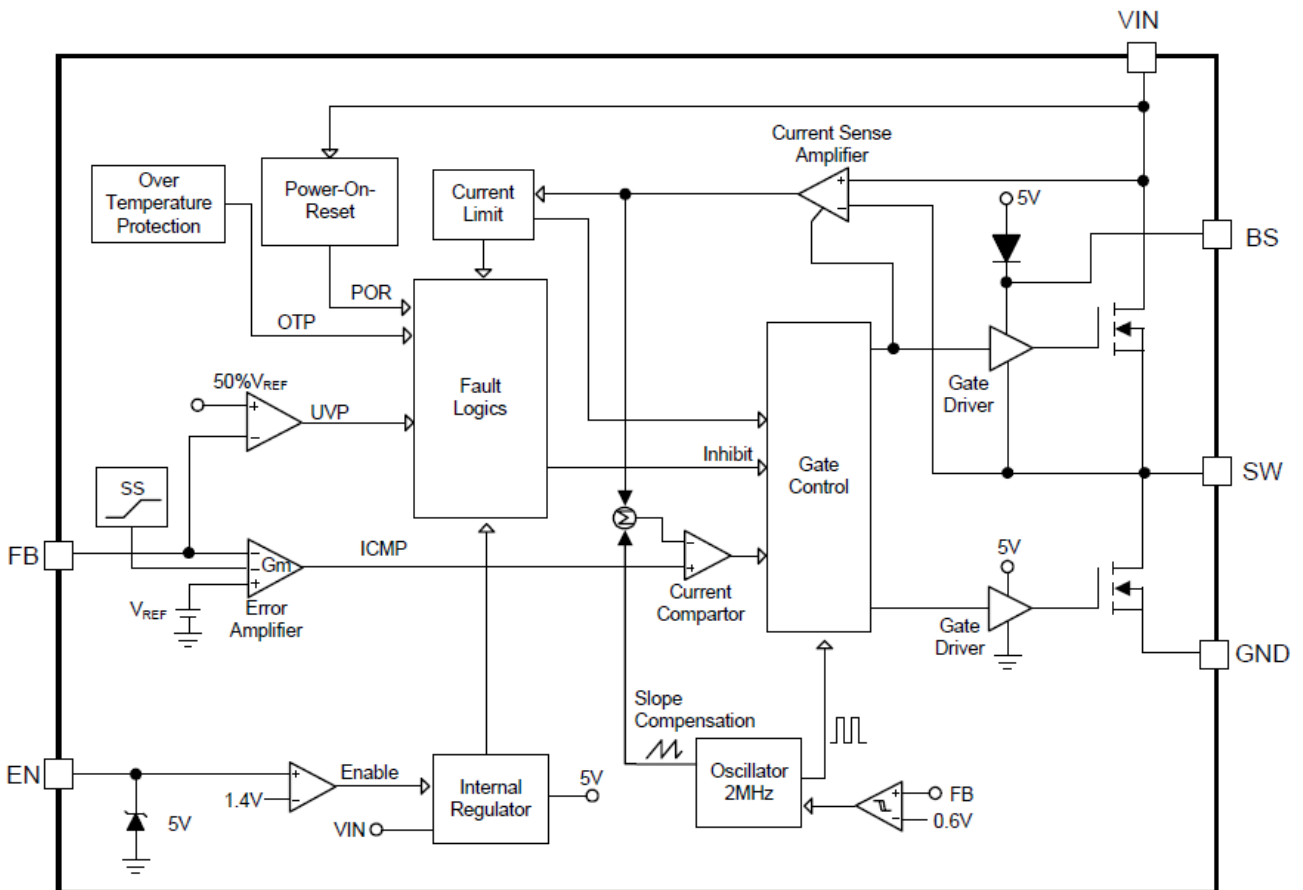

Figure 3 Function Block Diagram of TD1465

40V, 600mA, 2MHz/1MHz synchronous Buck Converter TD1465

Absolute Maximum Ratings ^{Note1}

Symbol	Parameter	Rating	Unit
V _{IN}	VIN Supply Voltage (VIN to GND)	-0.3 ~ 45	V
V _{SW}	SW to GND Voltage	Pulse Width > 20ns	-1 ~ 45
		Pulse Width < 20ns	-3 ~ 45
	EN, FB to GND Voltage	-0.3 ~ 6	V
V _{BS}	BS to GND Voltage	V _{SW} -0.3 ~ V _{SW} +6	V
V _{BS-SW}	BS to SW Voltage	-0.3 ~ 6	V
P _D	Power Dissipation	Internally Limited	W
T _J	Junction Temperature	150	°C
T _{STG}	Storage Temperature	-65 ~ 150	°C
T _{SDR}	Maximum Lead Soldering Temperature (10 Seconds)	260	°C

Note1: Stresses beyond those listed under "absolute maximum ratings" may cause permanent damage to the device. These are stress ratings only and functional operation of the device at these or any other conditions beyond those indicated under "recommended operating conditions" is not implied. Exposure to absolute maximum rating conditions for extended periods may affect device reliability.

Thermal Characteristics

Symbol	Parameter	Typical Value	Unit
θ _{JA}	Junction-to-Ambient Resistance in free air ^(Note 2) SOT-23-6	250	°C/W

Note 2: θ_{JA} is measured with the component mounted on a high effective thermal conductivity test board in free air.

Recommended Operation Conditions ^{Note3}

Symbol	Parameter	Range	Unit
V _{IN}	VIN Supply Voltage	4.5 ~ 40	V
V _{OUT}	Converter Output Voltage	0.8V ~ 75%V _{IN}	V
I _{OUT}	Converter Output Current	Continue	0 ~ 300
		< 10ms	0 ~ 600
	V _{OUT} /V _{IN} Maximum Ratio ^{Note 4}	TD1465A	75
		TD1465B	65
	V _{OUT} /V _{IN} Minimum Ratio ^{Note 5}	TD1465A	12
		TD1465B	15
T _A	Ambient Temperature	-40 ~ 85	°C
T _J	Junction Temperature	-40 ~ 125	°C

Note 3: Refer to the typical application circuit

40V, 600mA, 2MHz/1MHz synchronous Buck Converter TD1465

Note 4: In applications where the VOUT/VIN ratio exceeds the Maximum Ratio and when output loading is sufficient to make the converter enter PWM mode, the VOUT voltage will probably drop.

Note 5: When operating below the VOUT/VIN Minimum Ratio, the converter has the likelihood of entering PSM mode in spite of loading is heavy. However, in PSM mode, the VOUT voltage is still regulated well.

Electrical Characteristics

Unless otherwise specified, these specifications apply over VIN=12V, VEN=3V and TA= -40 to 85 °C. Typical values are at TA=25°C.

Symbol	Parameter	Test Conditions	TD1465A/B			Unit
			Min	Typ	Max	
SUPPLY CURRENT						
I _{VIN}	VIN Supply Current	V _{FB} =1V, SW=NC	-	0.5	1.0	mA
I _{VIN_SD}	VIN Shutdown Supply Current	V _{EN} =0V	-	1	10	μA
POWER-ON-RESET (POR)						
	VIN POR Voltage Threshold	V _{IN} Rising	3.7	3.9	4.1	V
	VIN POR Hysteresis		-	0.6	-	V
REFERENCE VOLTAGE						
V _{REF}	Reference Voltage		-	0.8	-	V
	Output Voltage Accuracy	T _J =25°C, I _{OUT} =10mA	-3	-	+3	%
I _{FB}	FB input current		-	10	50	nA
OSCILLATOR AND DUTY CYCLE						
F _{SW}	Switching Frequency	TD1465B	1600	2000	2400	kHz
		TD1465A	800	1000	1200	kHz
D _{MAX}	SW Maximum Duty Cycle ^{Note6}		80	-	-	%
	Minimum on-time		-	60	80	ns
POWER MOSFET						
	High Side MOSFET Resistance		-	900	-	mΩ
	Low Side MOSFET Resistance		-	900	-	mΩ
	High Side Switch Leakage Current	V _{EN} =0V, V _{IN} =40V, V _{SW} =0V	-	-	2	μA
	Low Side Switch Leakage Current	V _{EN} =0V, V _{IN} =40V, V _{SW} =40V	-	-	2	μA
	Dead-time		-	10	-	ns

Electrical Characteristics(Cont.)

Unless otherwise specified, these specifications apply over $V_{IN}=12V$, $V_{EN}=3V$ and $T_A=-40$ to 85 °C. Typical values are at $T_A=25$ °C.

Symbol	Parameter	Test Conditions	TD1465A/B			Unit
			Min	Typ	Max	
PROTECTIONS						
I_{LIM}	High Side MOSFET Current-Limit		1.2	1.5	1.8	A
	Under-Voltage Protection (UVP)		40	50	60	% V_{REF}
	Over-Temperature Protection		-	150	-	°C
	Over-Temperature Hysteresis		-	30	-	°C
SOFT-START, ENABLE						
t_{SS}	Soft Start Time		-	1	-	ms
	EN Rising Threshold Voltage	$V_{IN}=4.5V \sim 40V$	1.2	1.4	1.6	V
	EN Falling Threshold Hysteresis	$V_{IN}=4.5V \sim 40V$	-	0.2	-	V
	EN Turn on delay		-	50	-	us
	EN Input Current	$V_{EN}=2V$	-	2	-	uA
	EN Clamp High		4	5	6	V
	EN Input Current	$V_{EN}=6V$	-	-	10	μA

Note 6: Supec guarantee the SW maximum duty cycle. The maximum percentage of converter output over input voltage depends on load current.

Typical Application Circuit

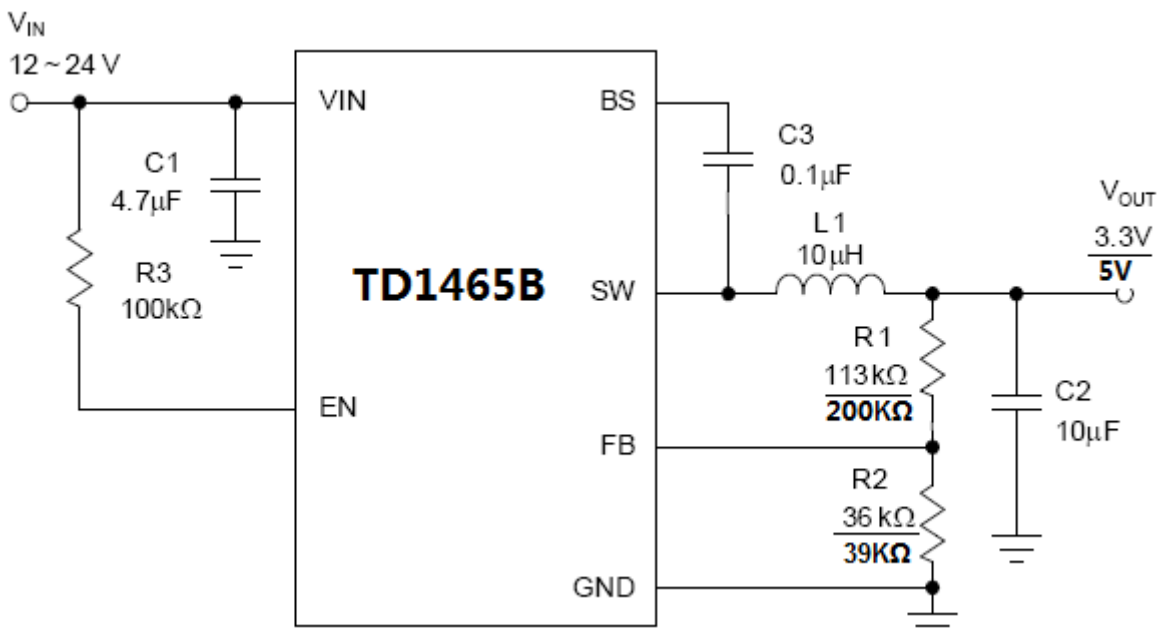
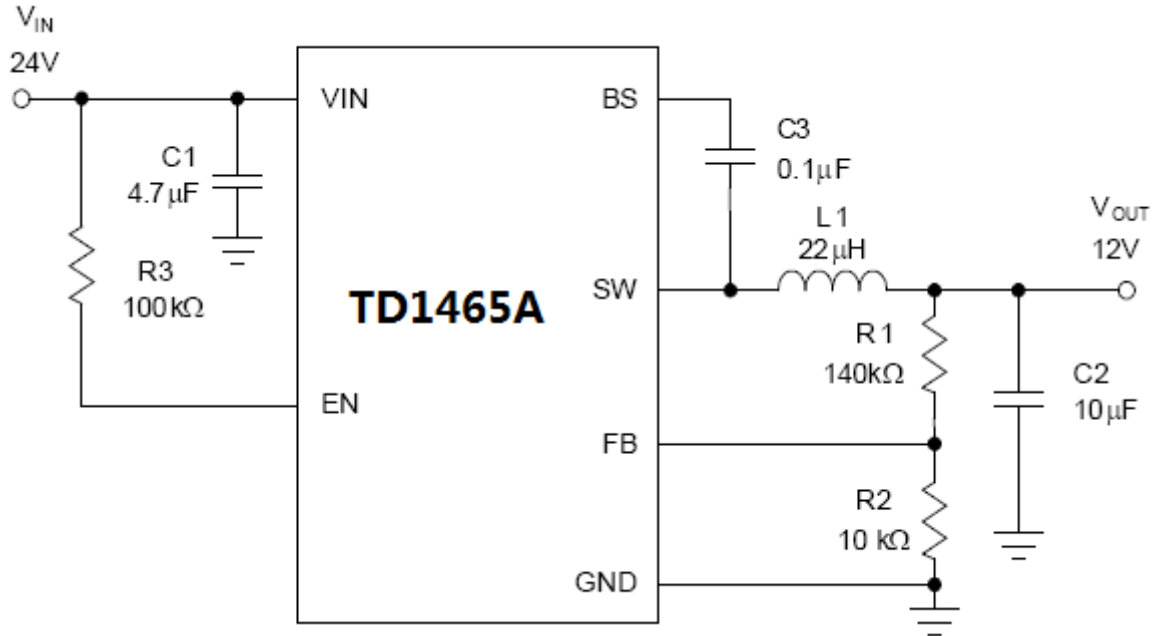

Function Description

Main Control Loop

The TD1465 is a constant frequency, synchronous rectifier and current-mode switching regulator. In normal operation, the internal upper power MOSFET is turned on each cycle. The peak inductor current at which ICMP turn off the upper MOSFET is controlled by the voltage on the COMP node, which is the output of the error amplifier (EAMP). An external resistive divider connected between V_{OUT} and ground allows the EAMP to receive an output feedback voltage V_{FB} at FB pin. When the load current increases, it causes a slightly decrease in V_{FB} relative to the 0.8V reference, which in turn causes the COMP voltage to increase until the average inductor current matches the new load current.

VIN Power-On-Reset (POR) and EN Under-voltage Lockout

The TD1465 keep monitoring the voltage on VIN pin to prevent wrong logic operations which may occur when VIN voltage is not high enough for the internal control circuitry to operate. The VIN POR has a rising threshold of 3.9V (typical) with 0.6V of hysteresis.

An external under-voltage lockout (UVLO) is sensed and programmed at the EN pin. The EN UVLO has a rising threshold of 1.4V with 0.2V of hysteresis. The EN UVLO should be programmed by connecting a resistive divider from VIN to EN to GND.

After the VIN and EN voltages exceed their respective voltage thresholds, the IC starts a start-up process and then ramps up the output voltage to the setting of output voltage. Connect a RC network from EN to GND to set a turn-on delay that can be used to sequence the output voltages of multiple devices.

Soft-Start

The TD1465 provides built-in soft-start function to limit the inrush current. The soft-start time is 1ms.

Bootstrap Capacitor

The TD1465 is a N-channel MOSFET step down converter. The MOSFET requires a gate voltage that is higher than input voltage, thus a boost capacitor should be connected between SW and BST pins to drive the gate of the N-channel MOSFET. Typical bootstrap capacitor value is from 10nF to 100nF.

Over-Current-Protection and Hiccup

The TD1465 has a cycle-by-cycle over-current limit when the inductor current peak value exceeds the set current limit threshold. Meanwhile, the output voltage drops until FB is below the Under-Voltage (UV) threshold below the reference. Once UV is triggered, the TD1465 enters hiccup mode to periodically restart the part. This protection mode is especially useful when the output is dead-shortened to ground. The average short circuit current is greatly reduced to alleviate thermal issues and to protect the regulator. The TD1465 exits the hiccup mode once the over-current condition is removed.

Over-Temperature Protection (OTP)

The over-temperature circuit limits the junction temperature of the TD1465. When the junction temperature exceeds 150°C, a thermal sensor turns off the N-channel power MOSFET, allowing the device to cool down. The thermal sensor allows the converter to start a start-up process and regulate the output voltage again after the junction temperature cools by 30°C. The OTP designed with a 30°C hysteresis lowers the average T_J during continuous thermal overload conditions, increasing life time of the TD1465.

Package Information

SOT23-6 Package Outline Dimensions

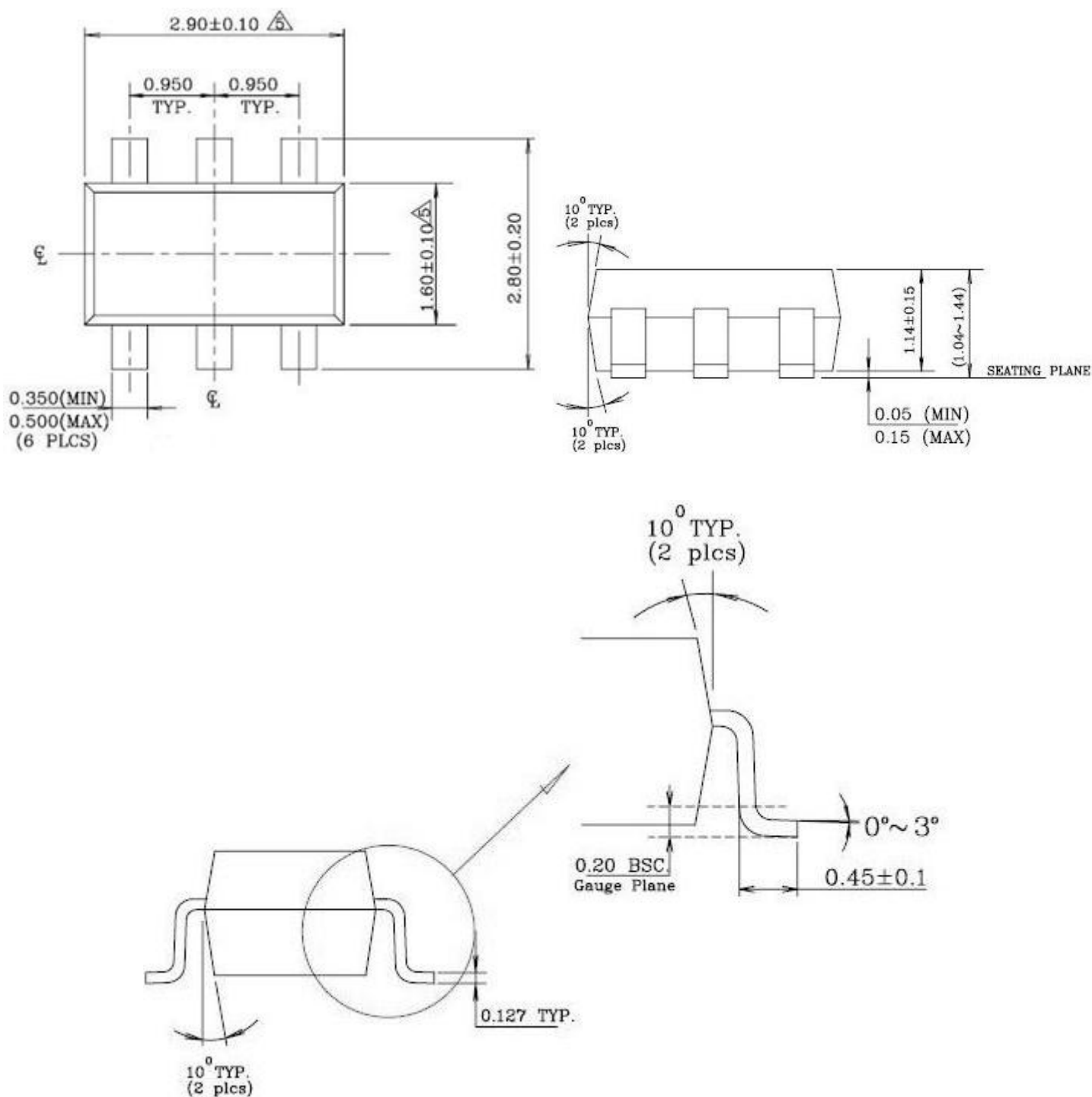

Design Notes