

# D款，正向10.0后两脚，DIP-\*6.50

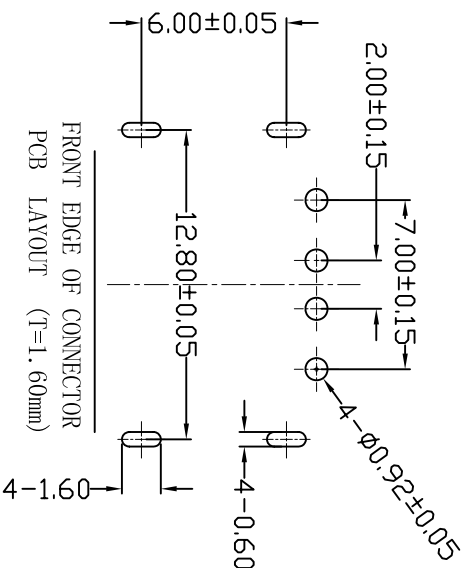
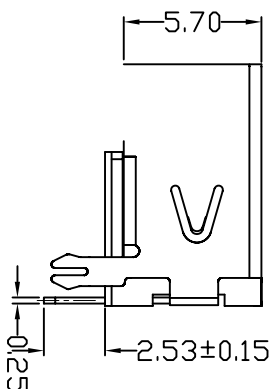
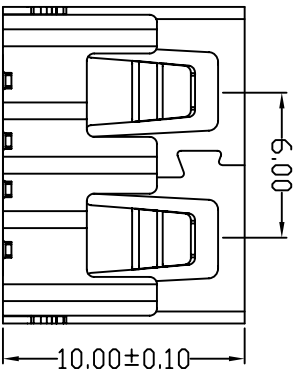
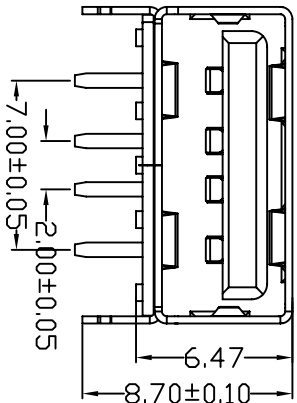
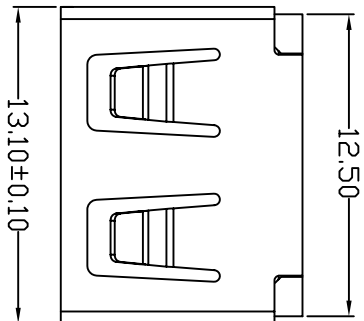

FRONT EDGE OF CONNECTOR  
PCB LAYOUT (T=1.60mm)

- NOTES:
- HOUSING: SEE NOTES, UL94V-0.
  - TERMINAL: SEE NOTES.
  - SHELL: SEE NOTES.
- SPECIFICATION:
- ELECTRICAL CHARACTERISTIC:
    - CONTACT RESISTANCE: 30MΩ MAX
    - DIELECTRIC WITHSTANDING VOLTAGE: 500V AC FOR 1MIN
    - INSULATION RESISTANCE: 1000MΩ MIN
  - MECHANICAL CHARACTERISTIC:
    - INSERTION FORCE: 35N(3.57KGf) MAX
    - EXTRACTION FORCE: 10~35N(1.02~3.57KGf) MIN
    - DURABILITY: 1500 CYCLES EXTRACTION FORCE: 10~35N 5000 CYCLES MIN
    - 5000 CYCLES EXTRACTION FORCE: 3~35N
  - ENVIRONMENTAL:
    - OPERATING TEMPERATURE: -55°C~+85°C
  - Contact finish:
    - 01: Selective Gold Flash
    - 02: Selective Gold 3U"
    - 03: Selective Gold 5U"
    - 04: Selective Gold 15U"
    - 05: Selective Gold 30U"

## 产品图

## 深圳市精拓金电子有限公司

公差一览表		单位	制图	制图料号
TOLERANCE UNLESS OTHERWISE	UNITS	MM	DRAWING	PRODUCT PART NO.
X: ±0.15	X: ±5°		审核	JTJ-USB-10.0-003
X: ±0.10	X: ±2°	1:1	制图	产品名称
XX: ±0.05	XX: ±1°		核准	PRODUCT NO.
XXX: ±0.03	XXX: ±0.5°		日期	USB A/F 10.0无边后两脚鱼叉(方弹)
			DATE	角法
			2012.09.24	VER
			APPD	版本
				AD

MAPX	MODIFICATION	DATE